

# **BUILDINGENERGY BOSTON**

---

## **Creating Harmony: Overcoming Challenges in Passive House Multifamily Design**

**Nicole Schuster, Positive Trace Architecture  
Andrew Van Roo, Ashley McGraw Architects**

*Curated by Jean Carroon*

---

**Northeast Sustainable Energy Association (NESEA) | March 21, 2025**



**Andrew Van Roo**  
Associate Principal and Project Manager  
*Ashley McGraw Architects DPC*



**Nicole Schuster**  
Principal and Phius Certified Consultant  
*Positive Trace Architecture PLLC*



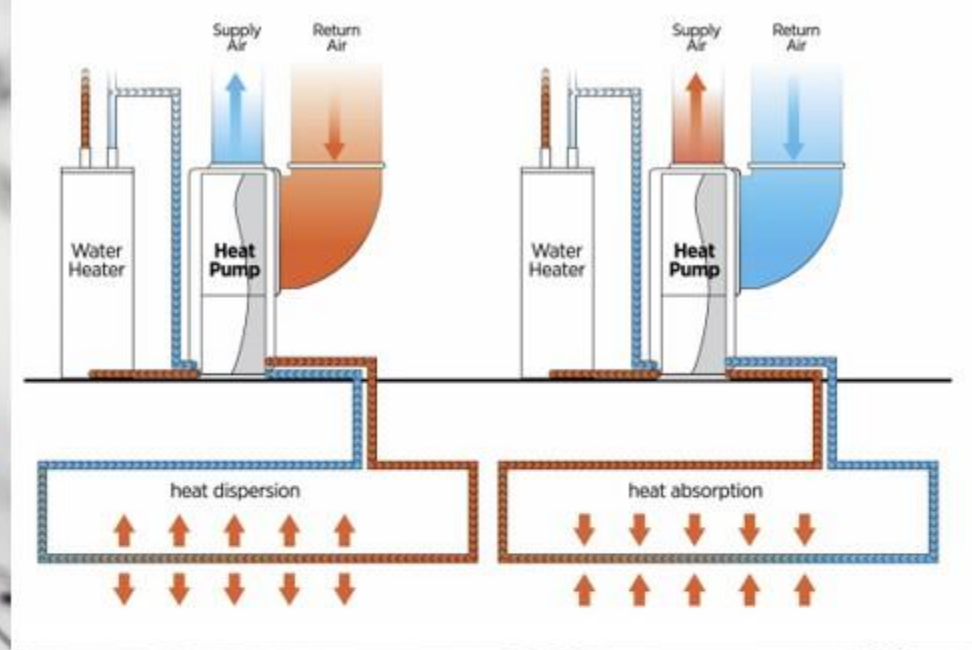
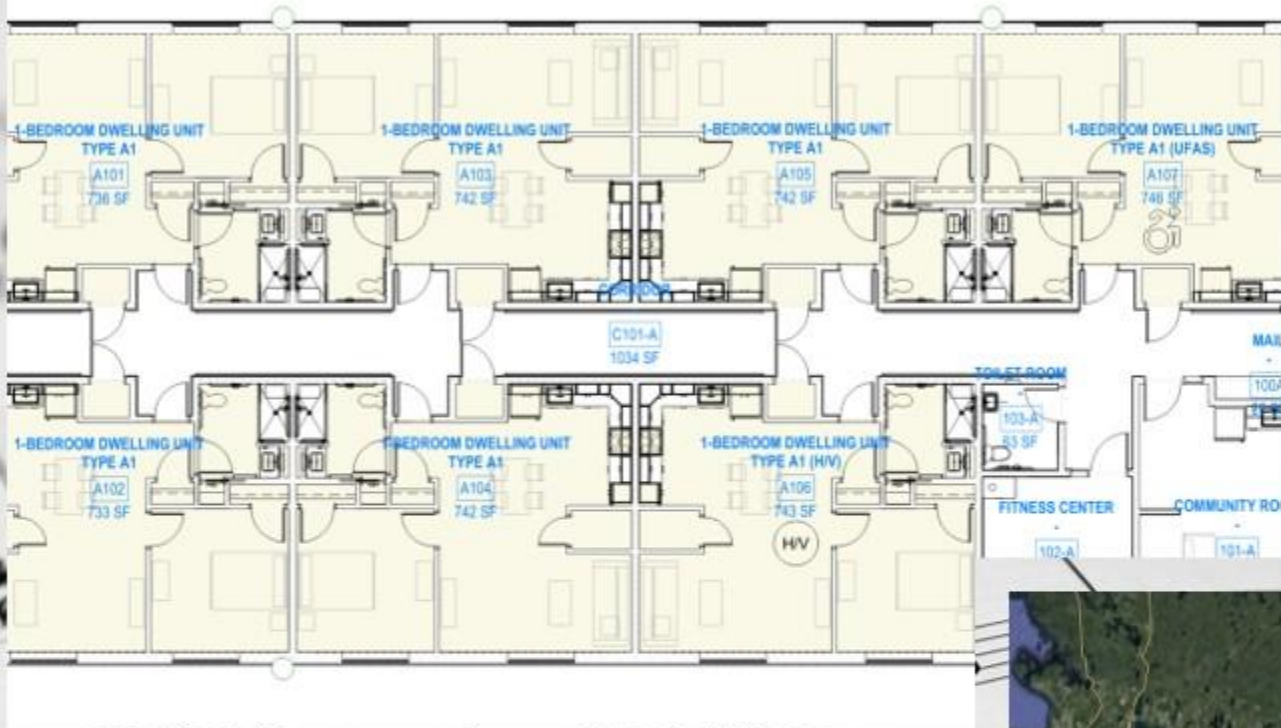

**phius 2021**  
**Custom Performance Criteria Calculator v3.3**

BUILDING FUNCTION	RESIDENTIAL
Climate Location	TANNERSVILLE, NY   5A
Envelope Area (sf)	27,858
iCFA (sf)	16,167
Dwelling Units (Count)	15
Total Bedrooms (Count)	15

**Space Conditioning Criteria**

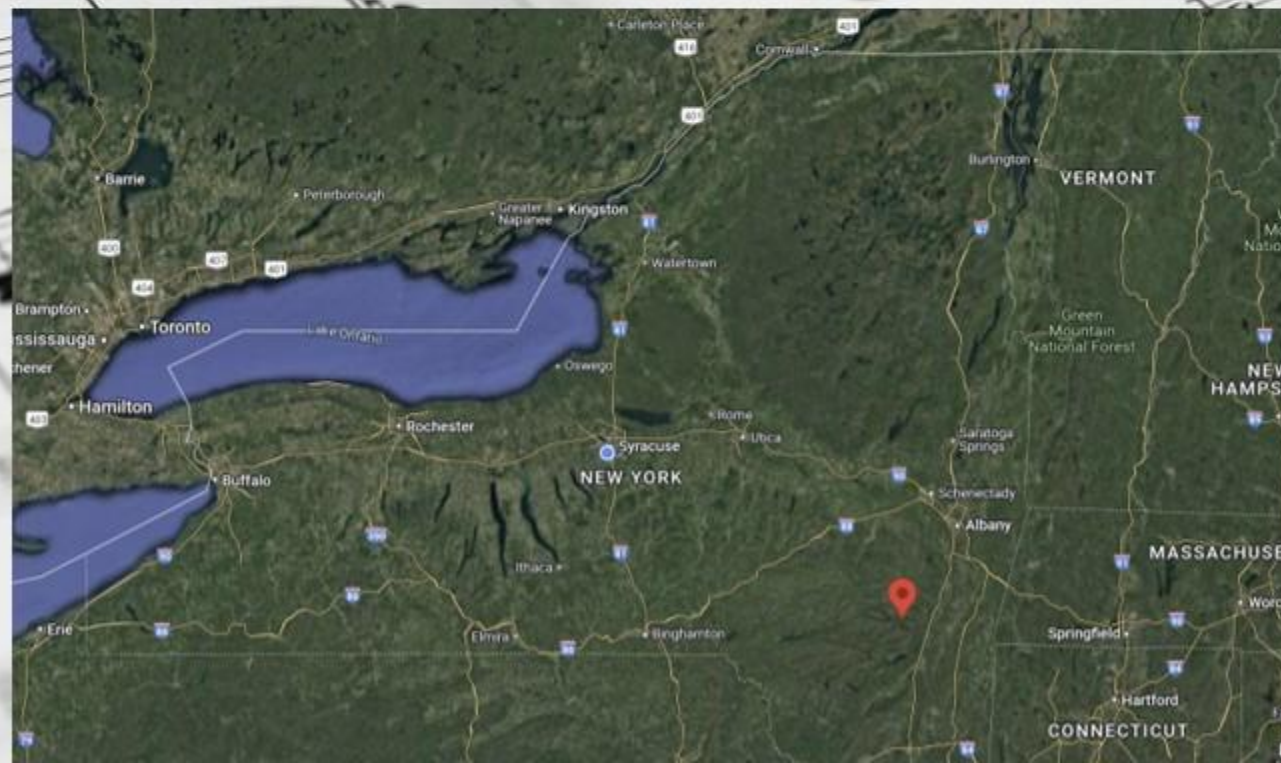



# Cold Spring Apartments

Tannersville, New York

# Cold Spring Apartments

Tannersville, New York

- 5.1 Acre Site
- 63,000 Gross Square Feet, Total
- Three (3) Buildings
  - Senior Housing: Fifteen (15) Units
  - Workforce Housing: Forty-Five (40) Units
  - Community Building: Leasing & Gathering
- Construction:
  - Two (2) Stories with Gabled Roofs
  - Double Loaded Corridors
  - Slab-on-Grade
  - Wood Framed

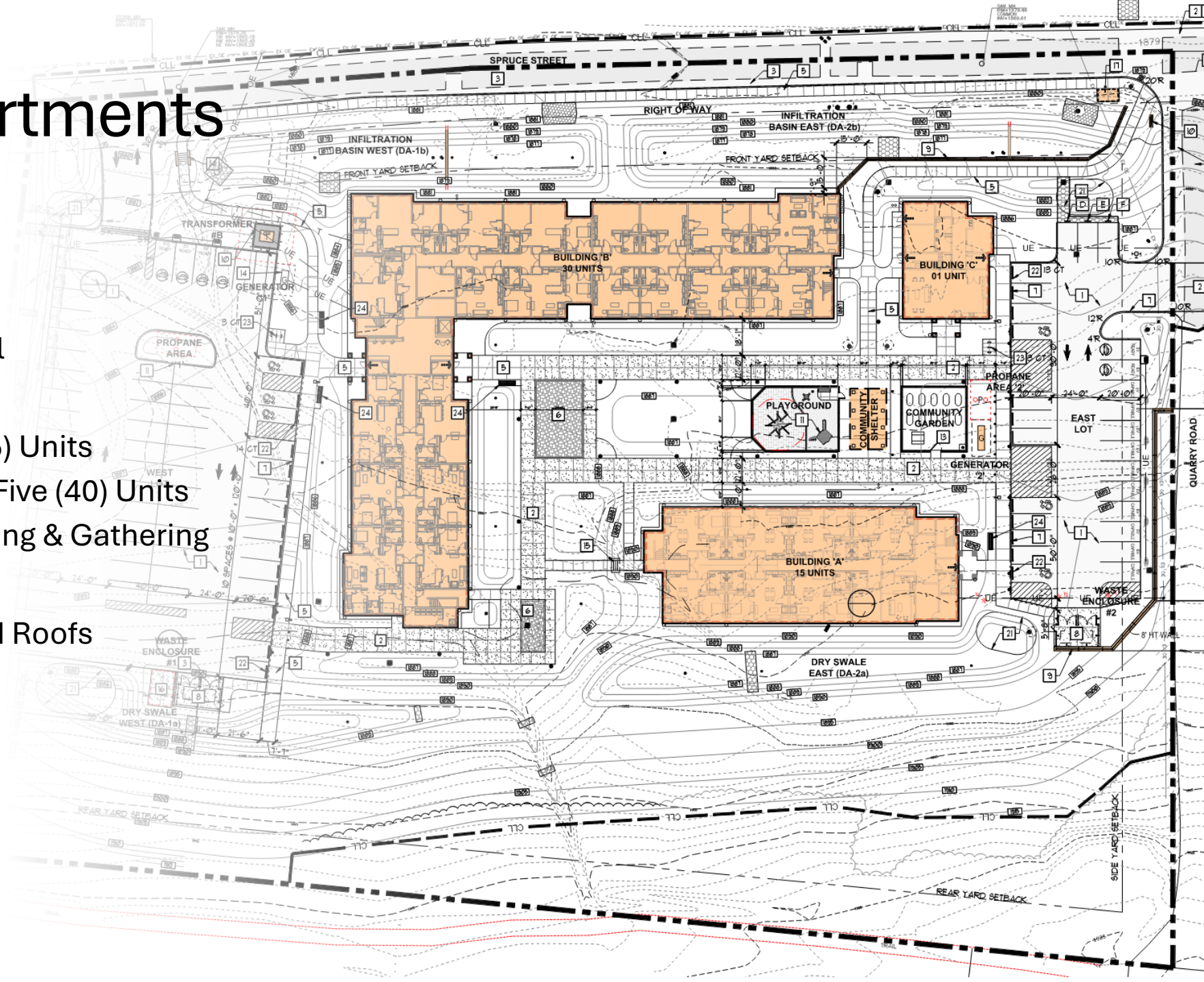

# The Audience

## *Regulatory Agencies*



**NYSERDA**



# The Band

*Project Team*



ASHLEY MCGRAW  
ARCHITECTS



A blurred background image of a conference room. A man in a light blue shirt is standing at the front, possibly presenting. The audience is seen from behind, with many people raising their hands, suggesting an interactive session or a Q&A period. The room has large windows in the background.

Who are You?





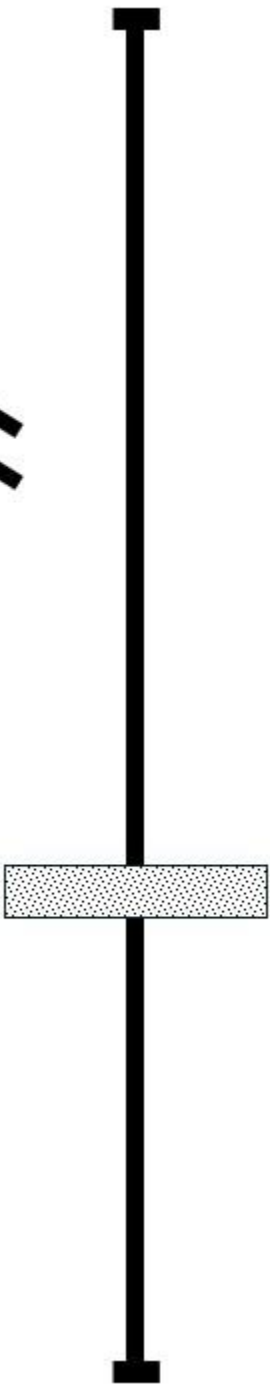
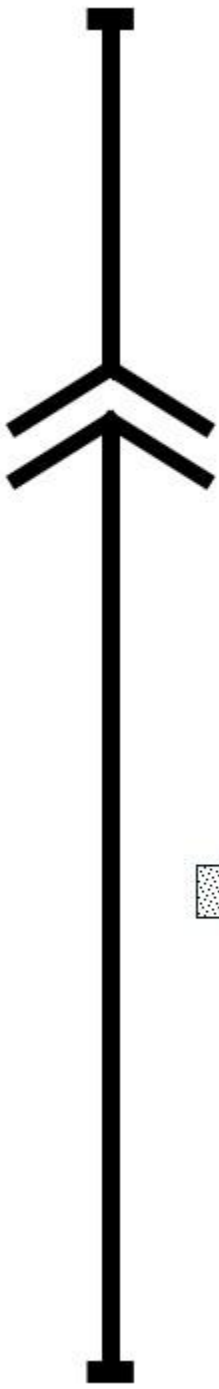

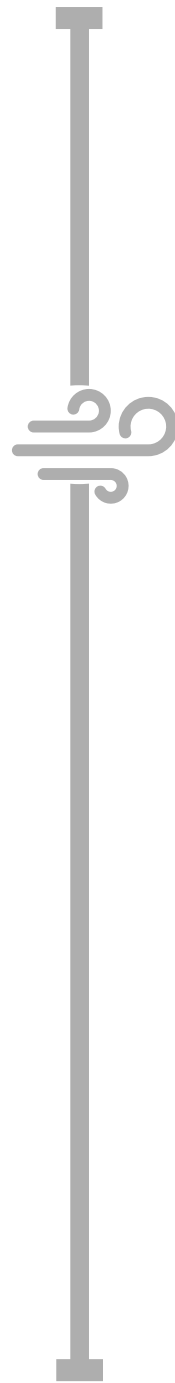
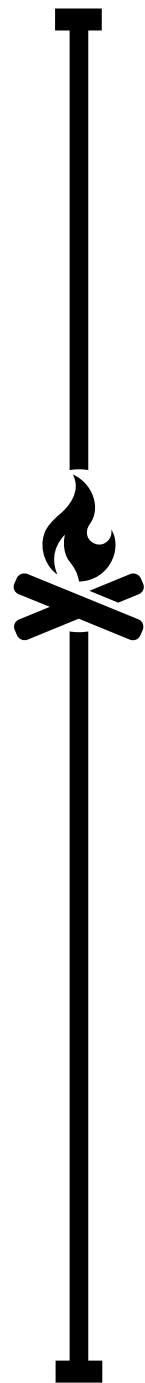
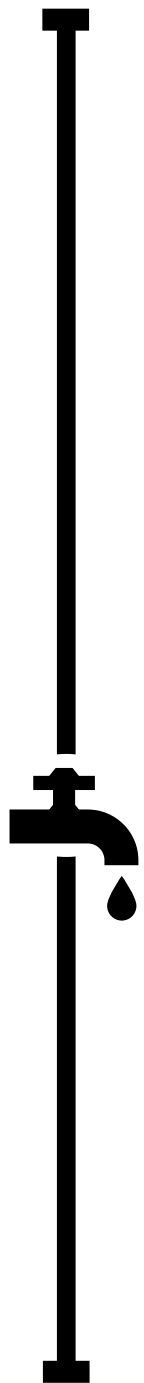
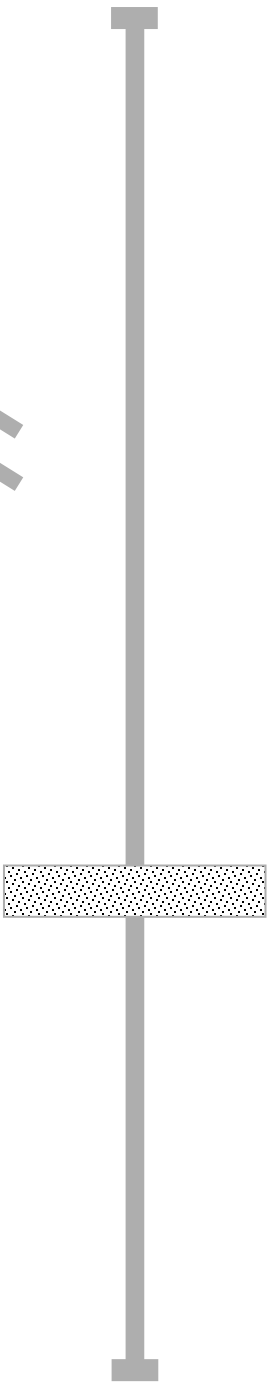
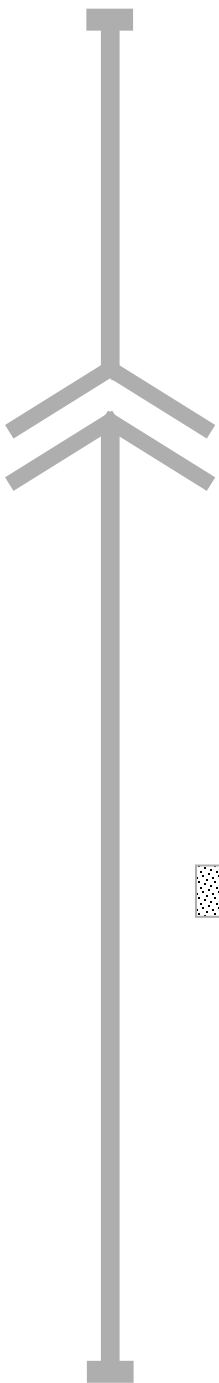
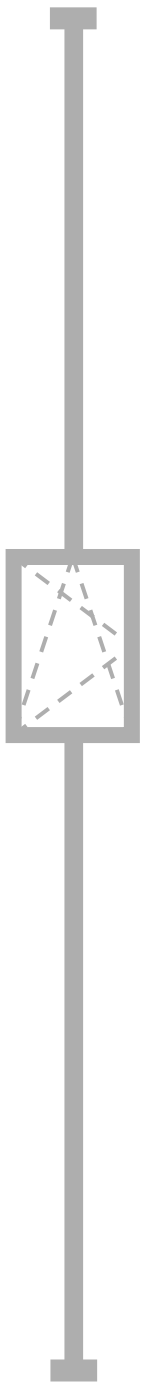

# Pumps

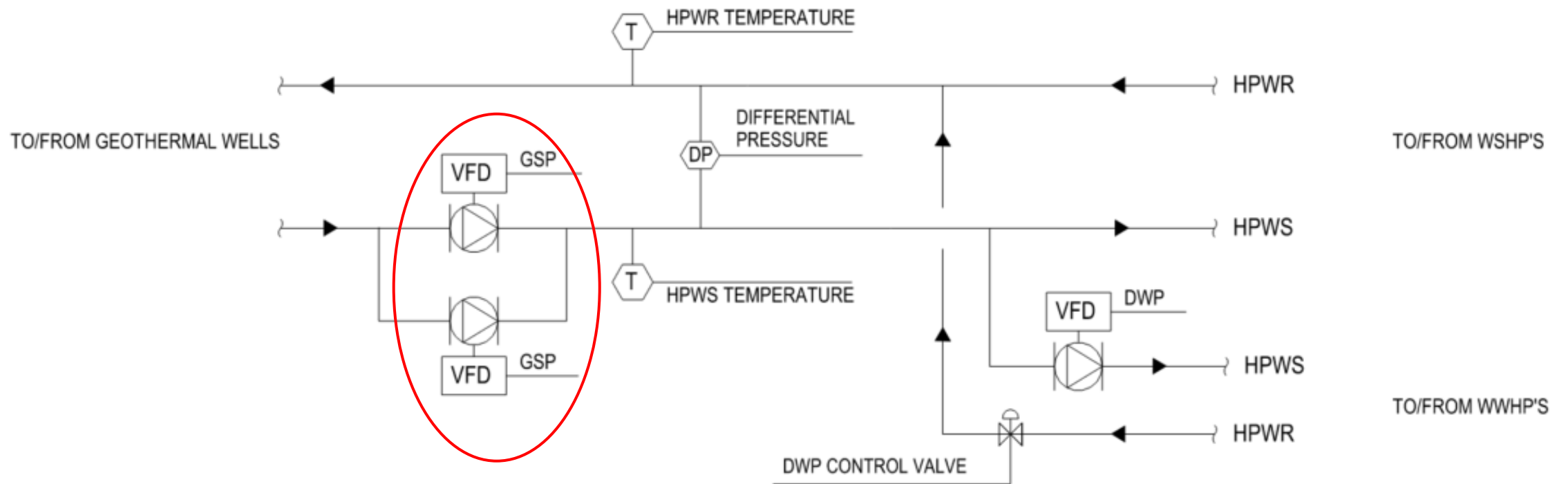

# Pumps

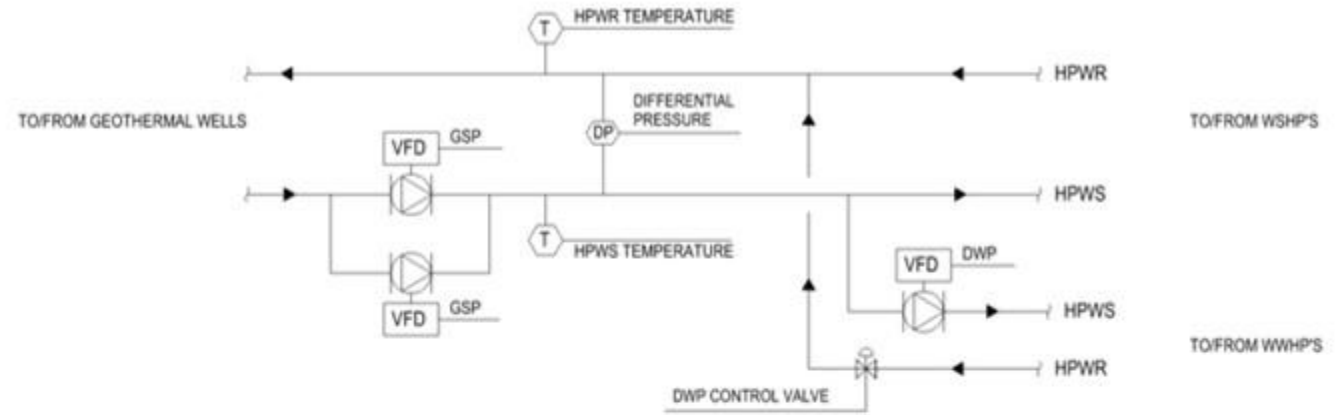

## Convert units

Power

3

Horsepower

= 2237.09962

Watt

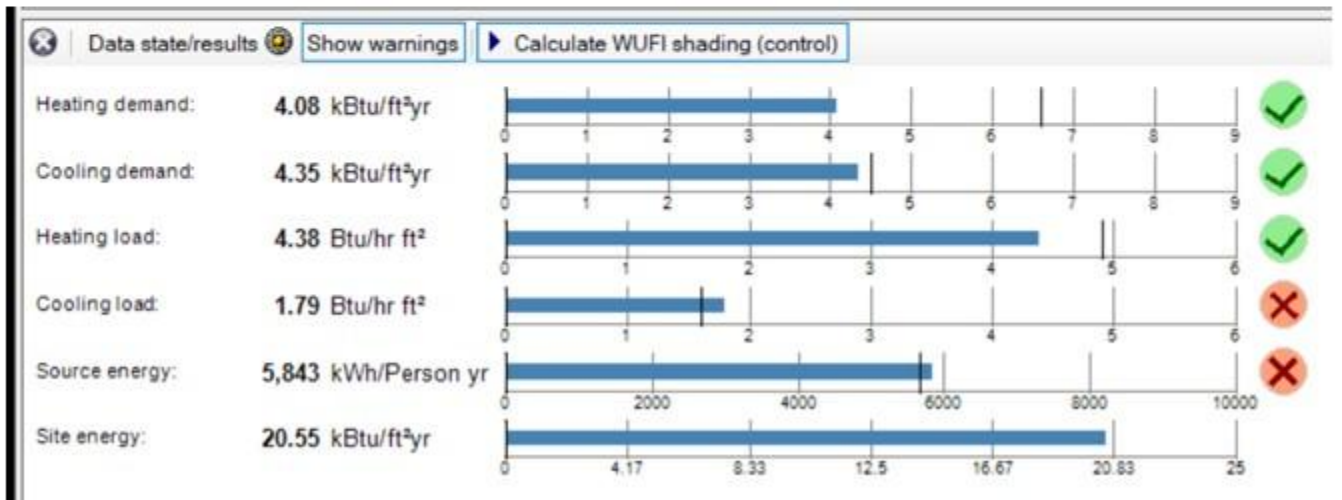

# Smaller Pumps

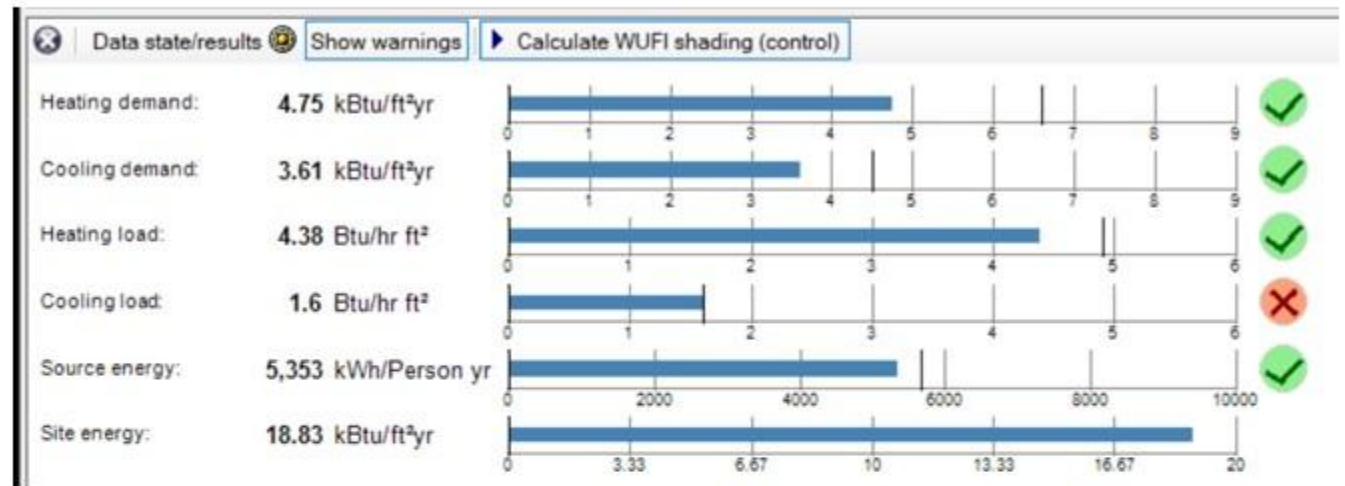

## Convert units

Power

.763

Horsepower

=

568.969002

Watt

Phius Ground Source Heat Pump Calculator			Required inputs				Calculated cells			
			Required dropdown menu inputs				Instructions			
Device(s)	Qty:	Power [W]		Power [kBtu/hr]		Total Power [kBtu/hr]		Effective Total Power [kBtu/hr]		
		Heating	Cooling	Heating	Cooling	Heating	Cooling	Heating	Cooling	
P-SP1	1	569.0	569.0	1.94	1.94	1.94	1.94	0.69	0.49	
				-	-			Complete 'Fan and Pump Run-Time Estimator' tab to update value above.		
				-	-					
				-	-					
				-	-					

# Phius Heat Pump Calculator

## Ground Source Heat Pump Performance Data

Include line items for each unique device type. Only include outdoor compressors and condensing units. Do not include interior heads or air handling units.

Performance data should be provided from the manufacturer or a third party rating like NEEP (<https://ashp.neep.org/#/>) or AHRI (<https://www.ahridirectory.org/Search/SearchHome?ReturnUrl=%2f>). Input data at the design conditions noted below.

Device(s)	Qty:	Heating Data				Cooling Data				
		Capacity [kBtu/hr]	Part Load COP	AND / OR	Full Load COP	Delivery Method	Capacity [kBtu/hr]	Part Load EER	AND / OR	Full Load EER
HP-1: Versatec 500 NB009	3	6.7		AND / OR	3.2	Recirculation Air	9.0		AND / OR	12.5
HP-2: Versatec 500 NB012	1	8.1		AND / OR	3.2	Recirculation Air	12.4		AND / OR	14.5
HP-3: Versatec 500 NB015	15	10.7		AND / OR	3.8	Recirculation Air	14.2		AND / OR	12.2
				AND / OR		Select			AND / OR	
				AND / OR		Select			AND / OR	
HP6: Versatec 500NC012	4	9.4		AND / OR	3.5	Recirculation Air	10.3		AND / OR	11.3

Phius Heat Pump Calculator		Required inputs	Calculated cells	Results
		Required dropdown menu inputs	Calculated cells from another sheet	Instructions

### Enter 'System Performance Data' below to attain Results for WUFI Passive.

Cooling via Recirculation Air		Units	System > Distribution > Cooling: Check the box for 'Cooling via air recirculation'.
Number of Systems Needed	1		Under Systems > Create the number of systems noted to the left and add a heat pump device to each system.
Space Cooling Coverage	1.00		Assign coverage to each new device created. If coverage is 0.33 (or similar), one input should be adjusted so the coverage sums to 1.
Total Recirculation Air Flow Rate	7316	cfm	Phius assumes 300 cfm of airflow per ton of cooling capacity.
ASHP Cooling Capacity	0	kBtu/hr	Informs the total capacity of the cooling via recirculation ventilation air.
GSHP Cooling Capacity	293		
Total Recirculation Air Cooling Capacity	293		Input the cooling capacity calculated to the left. A ton of cooling is equivalent to 12 kBtu/hr.
Weighted ASHP Cooling COP	0.00		The value calculated to the left is the weighted average COP for the cooling system as a whole.
Weighted GSHP Cooling COP	3.62		
Weighted Recirculation Cooling COP	3.62		

Heat Pump - rated monthly COP: ASHP		Units	
Space Heating Coverage:	0.00		If no heating provided via heat pump, no inputs required.
Weighted ASHP Heating COP 1	-		
Ambient Temperature 1	17	°F	
Weighted ASHP Heating COP 2	-		
Ambient Temperature 2	47	°F	

Heat Pump: GSHP		Units	
Space Heating Coverage:	1.00		If no heating provided via heat pump, no inputs required.
Weighted GSHP Heating COP	3.71		Under the heat pump device device noted above, set the Type to 'Heat Pump' and input values calculated to the left.
Total System performance ratio of heat generator	0.27		



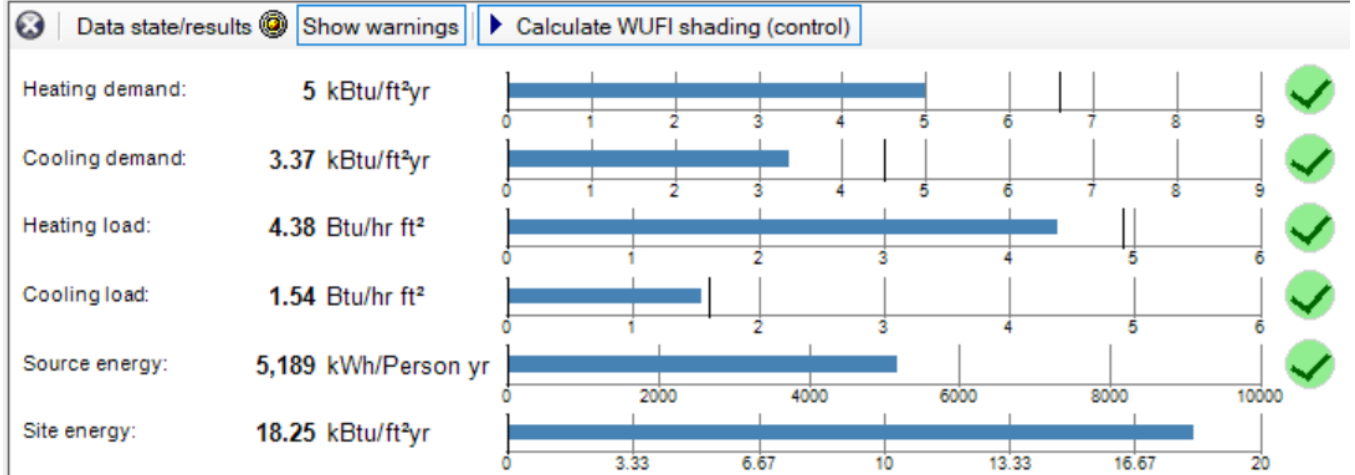
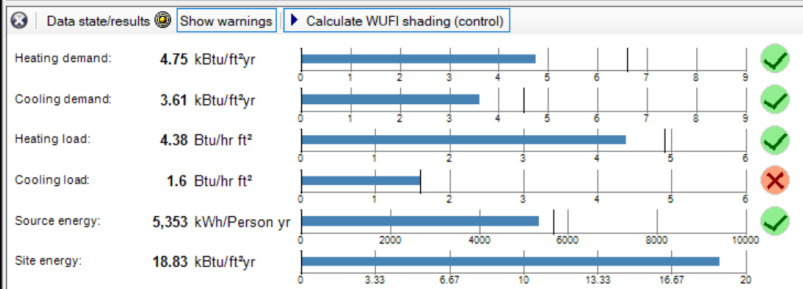
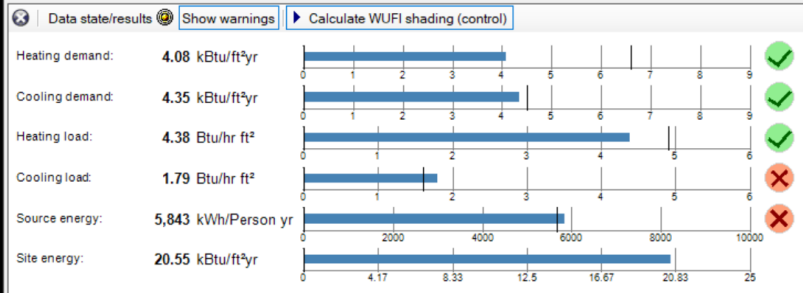

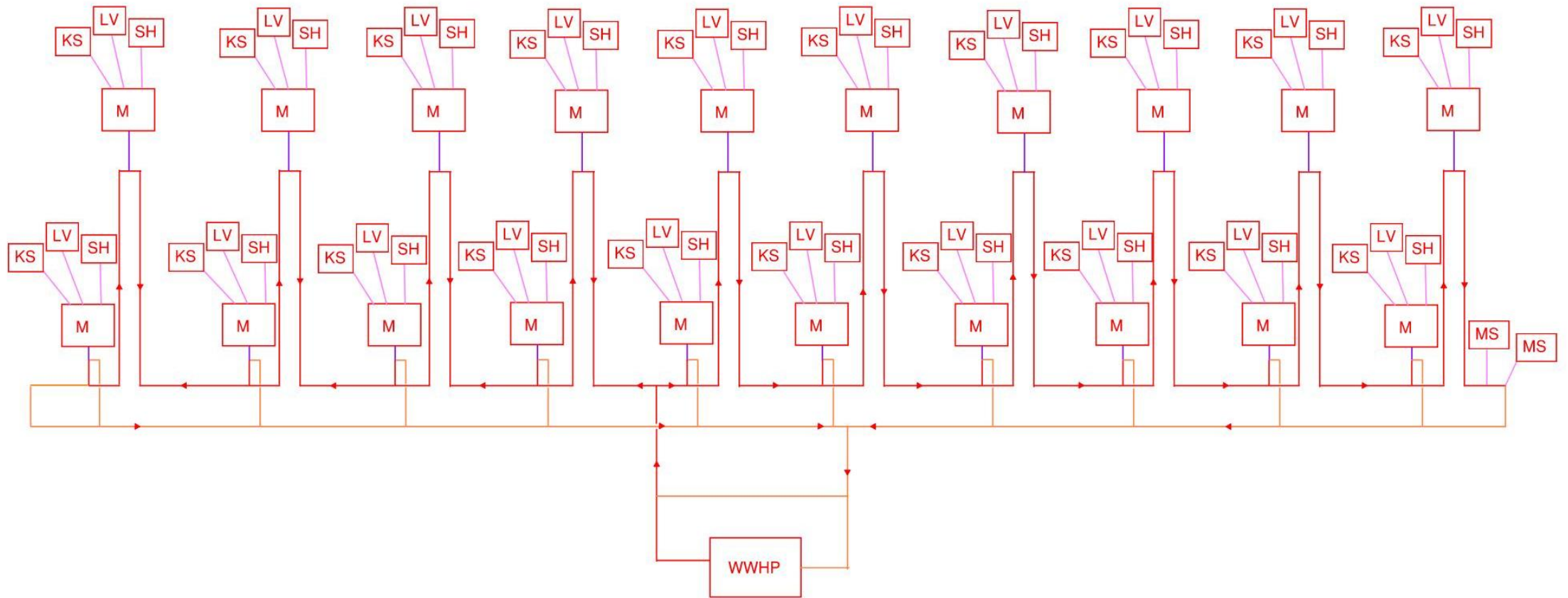

GSHPs - DHW

# Theory vs Practice

- Ground Source Closed Loop Systems (Exterior vs Interior)
- Measured Design vs Installer Experience
  - Quantity, Depth, & Location of Wells
  - NYS DEC Regulatory Requirements
  - Pipe Size
  - Glycol & Methanol
- Reduce Pumping Power Required

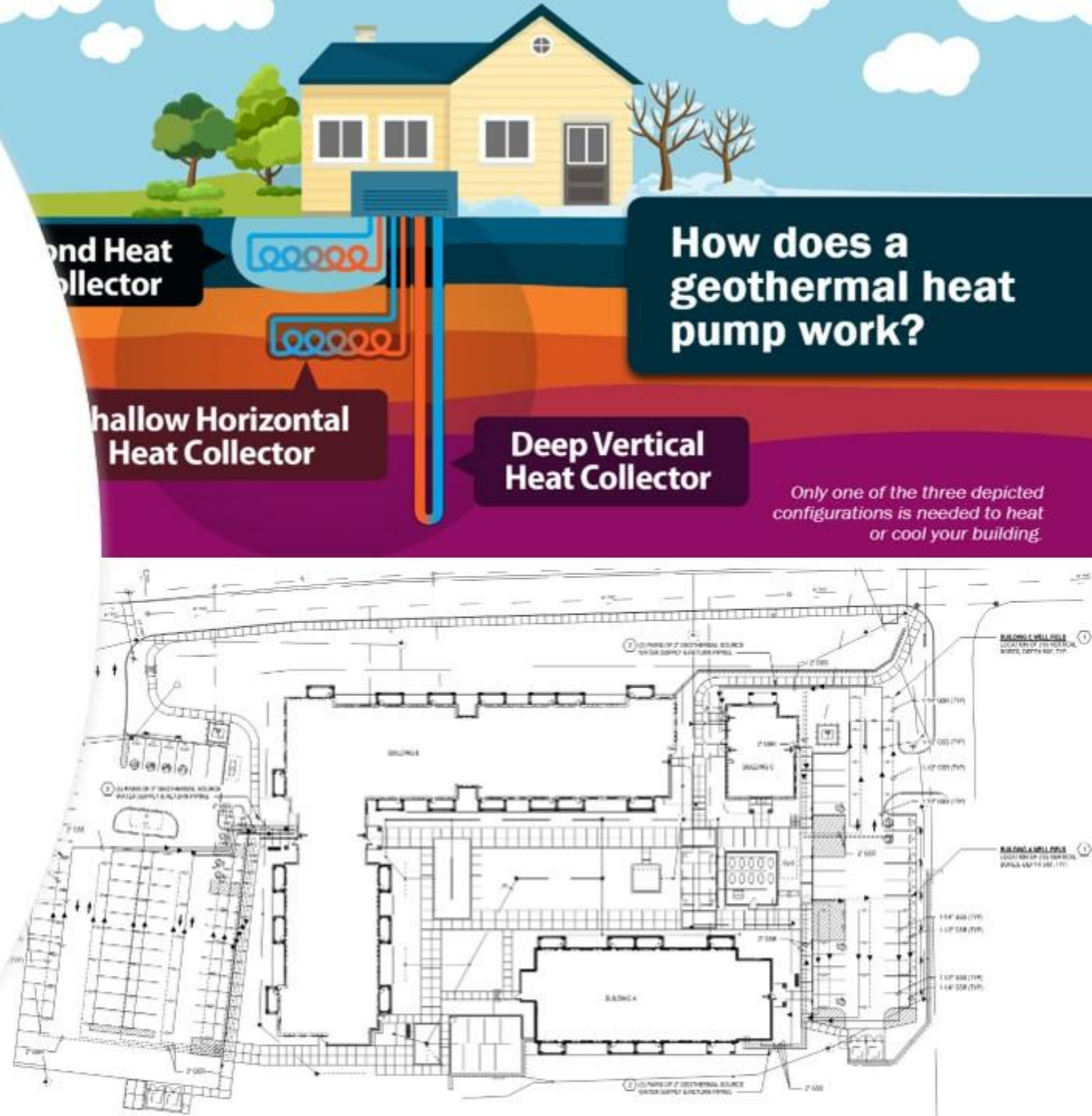

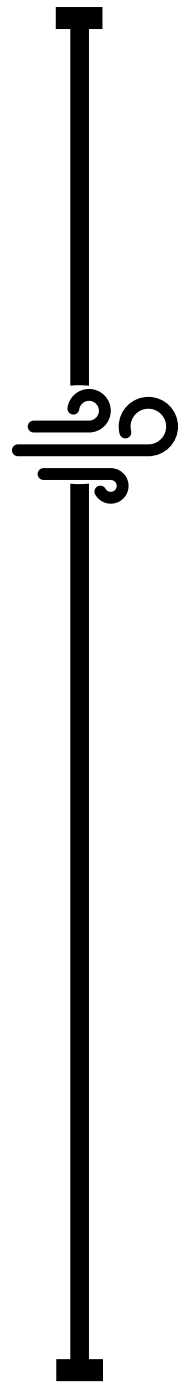
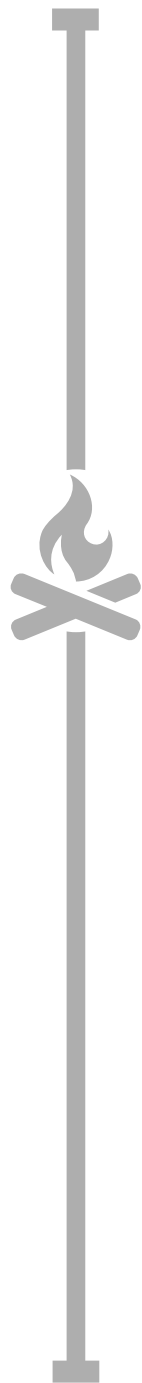
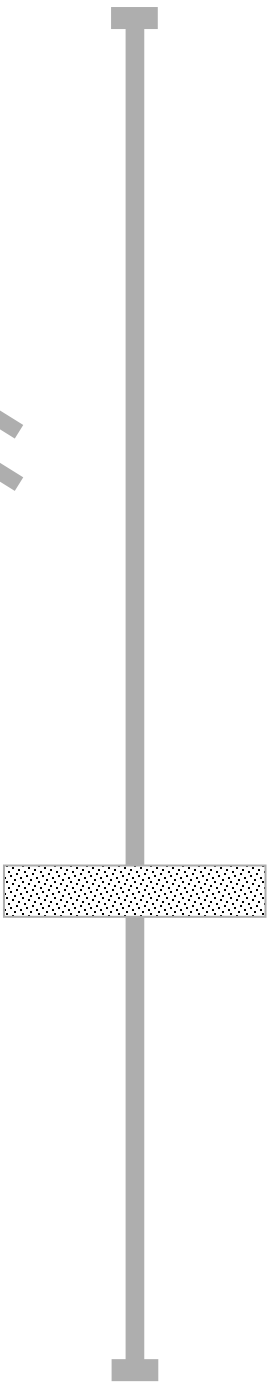
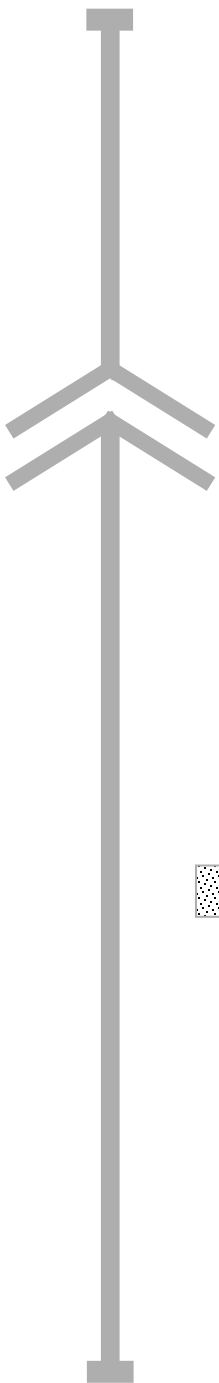
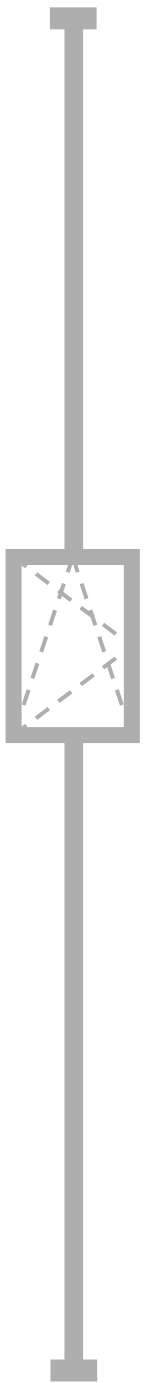

# As Designed

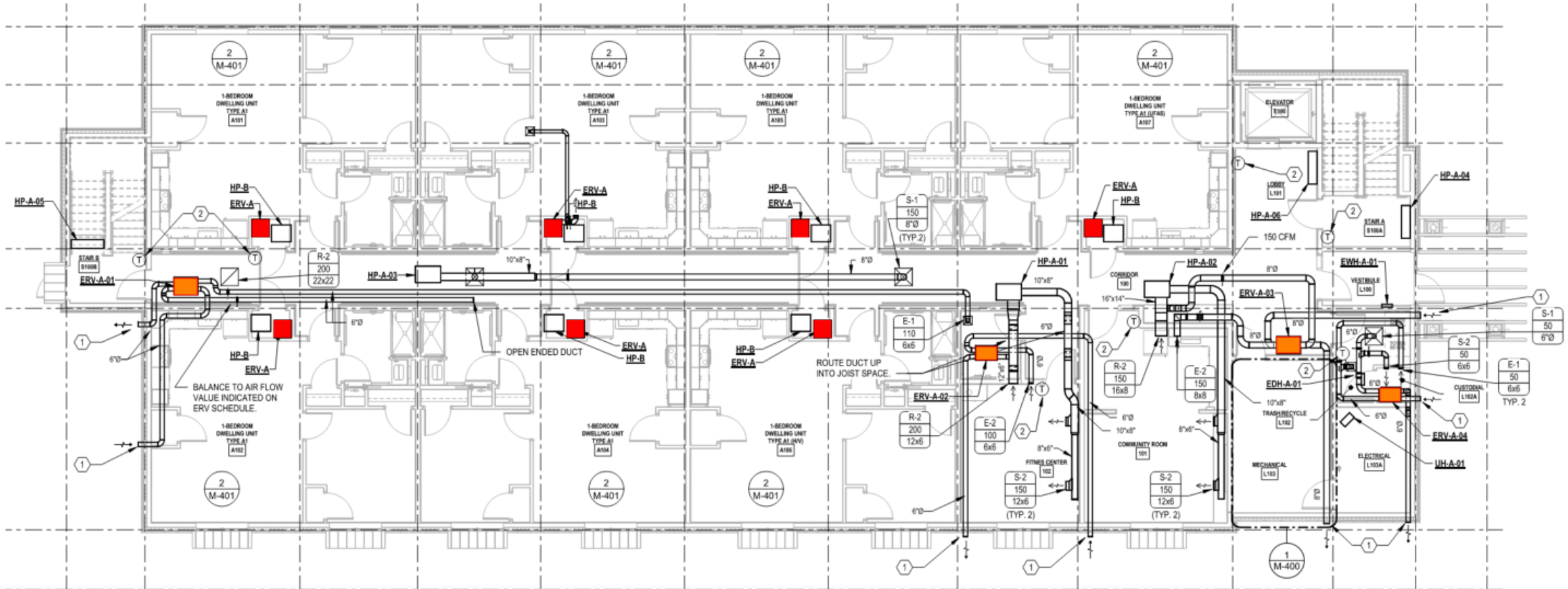

# ERVs – Equipment Efficiency - Units

EV Premium LH/EV Premium L – Energy Performance							
Supply Temperature		Net Airflow		Average Power Watts	Sensible Recovery Efficiency %	Adjusted Sensible Recovery Efficiency %	Net Moisture Transfer %
C°	F°	L/s	CFM				
<b>Heating</b>							
0°	32°	28	59	21	88	90	77
0°	32°	57	121	37	81	83	69
0°	32°	95	201	114	74	77	60
0°	32°	107	227	171	71	76	56
<b>Cooling</b>					Total Recovery Efficiency %	Adjusted Total Recovery Efficiency %	
35°	95°	29	61	20	76	77	

# ERVs – Equipment Efficiency – Common Areas

**SL75H/SL75 – Energy Performance**

Supply Temperature		Net Airflow		Average Power Watts	Sensible Recovery Efficiency %	Adjusted Sensible Recovery Efficiency %	Net Moisture Transfer %
C°	F°	L/s	CFM				
<b>Heating</b>							
0°	32°	24	51	30	78	82	64
0°	32°	36	76	50	74	79	56
0°	32°	47	100	79	70	75	50
<b>Cooling</b>					Total Recovery Efficiency %	Adjusted Total Recovery Efficiency %	
35°	95°	25	53	32	57	59	

**EV200 – Energy Performance**

Supply Temperature		Net Airflow		Average Power Watts	Sensible Recovery Efficiency %	Adjusted Sensible Recovery Efficiency %	Net Moisture Transfer %
C°	F°	L/s	CFM				
<b>Heating</b>							
0°	32°	85	180	146	74	79	57
<b>Cooling</b>					Total Recovery Efficiency %	Adjusted Total Recovery Efficiency %	
35°	95°	79	167	137	57	60	

# ERVs – Duct Runs

Studio (Bldg A: x0, Bldg B: x10)

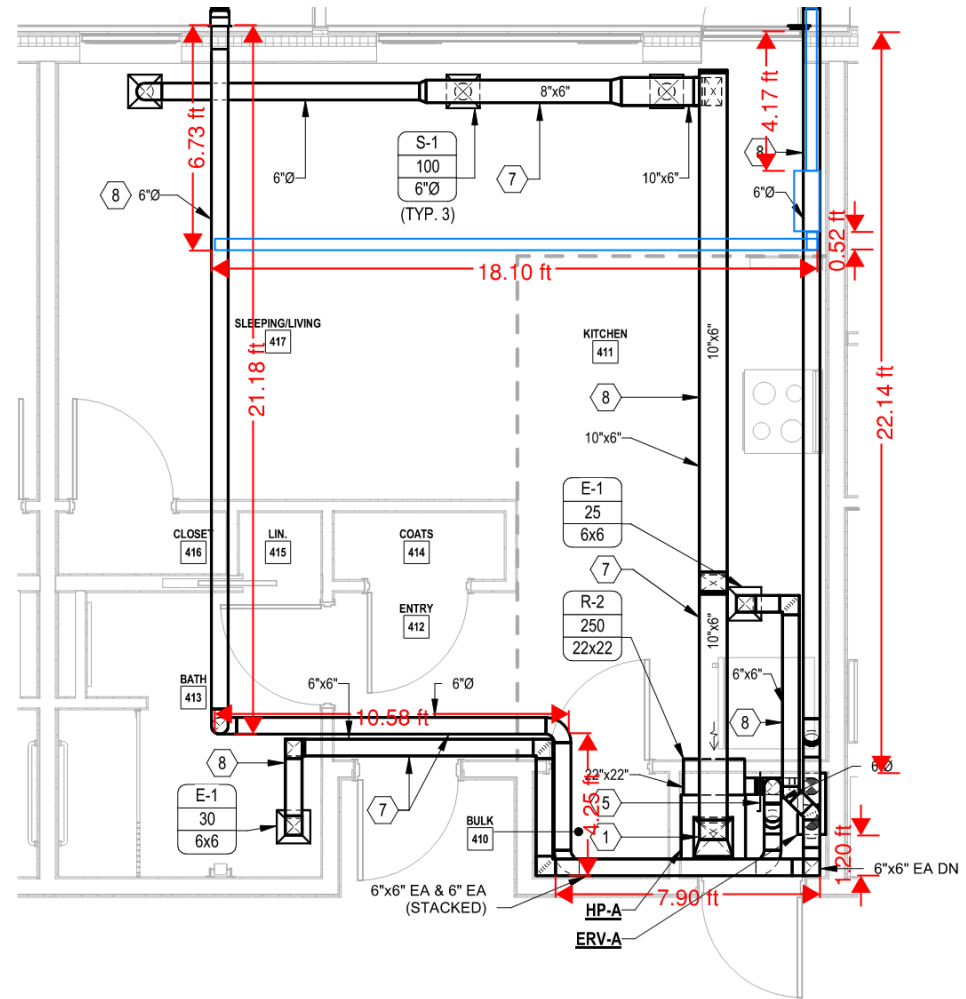



# ERVs – Duct Runs

1 Bedroom (Bldg A: x15, Bldg B: x16)

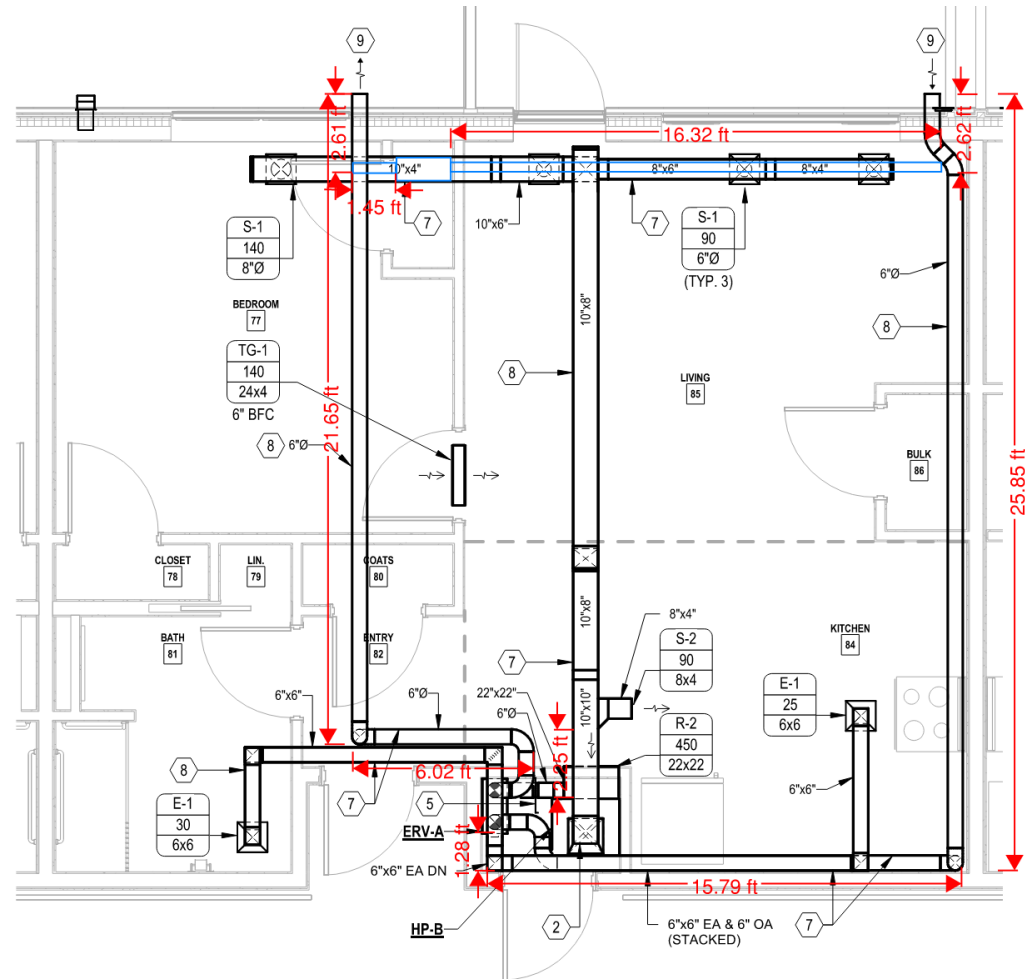

# ERVs – Duct Runs

2 Bedrooms (Bldg A: x0, Bldg B: x8)

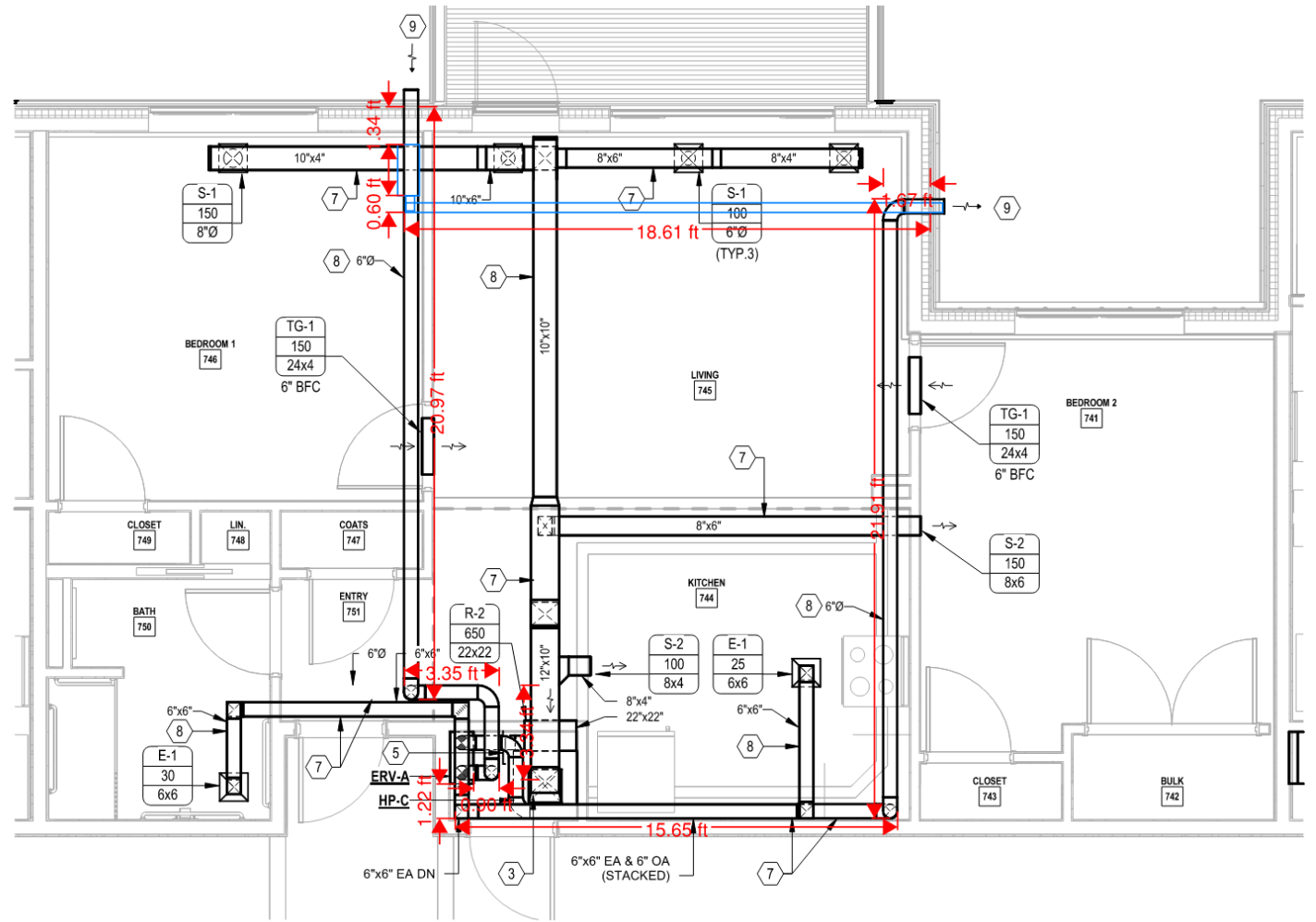

# ERVs – Duct Runs

3 Bedrooms (Bldg A: x0, Bldg B: x6)

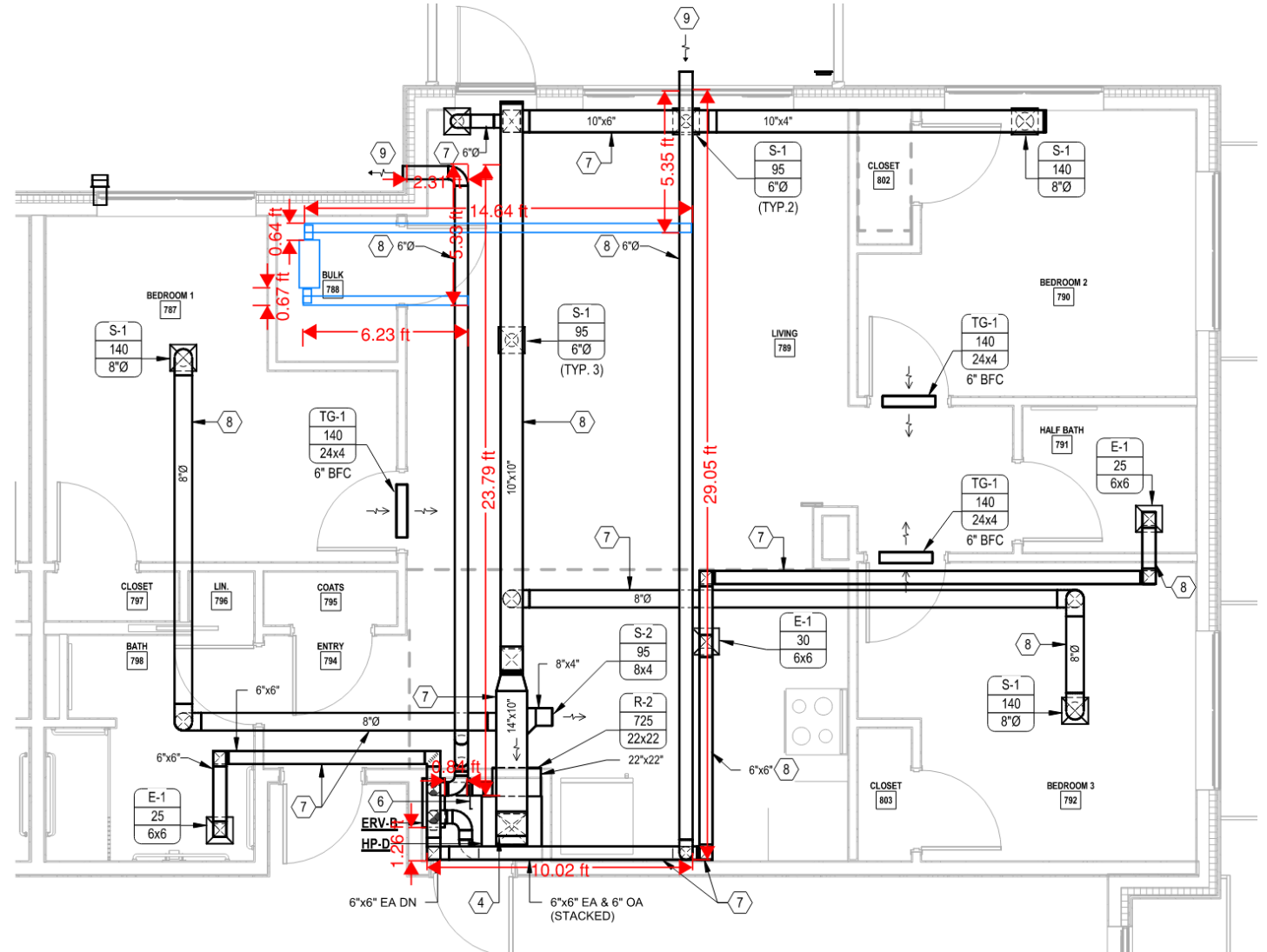

# Hindsight Options

- Individual ERVs
- Centralized ERVs
- Centralized with Enthalpy Controlled Bypass

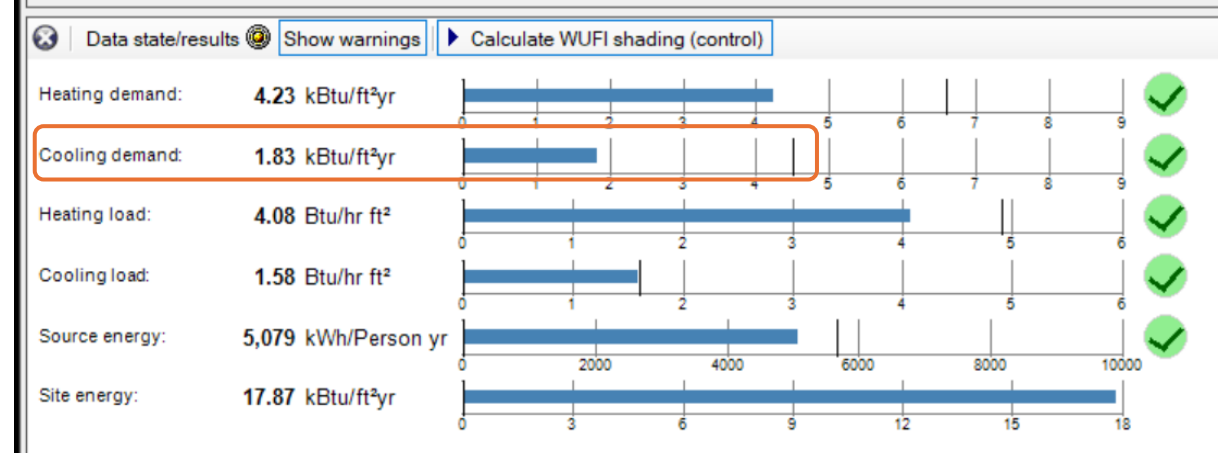
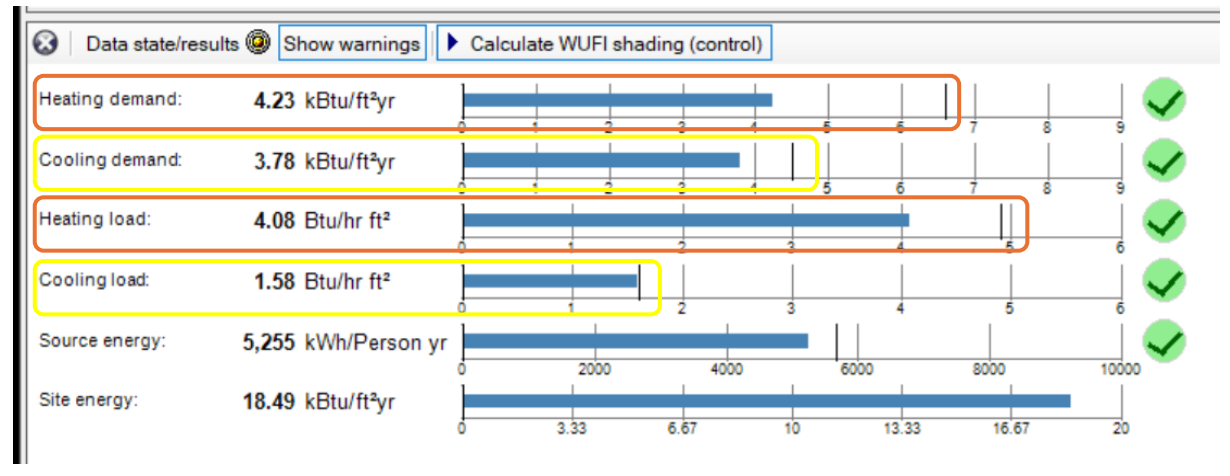
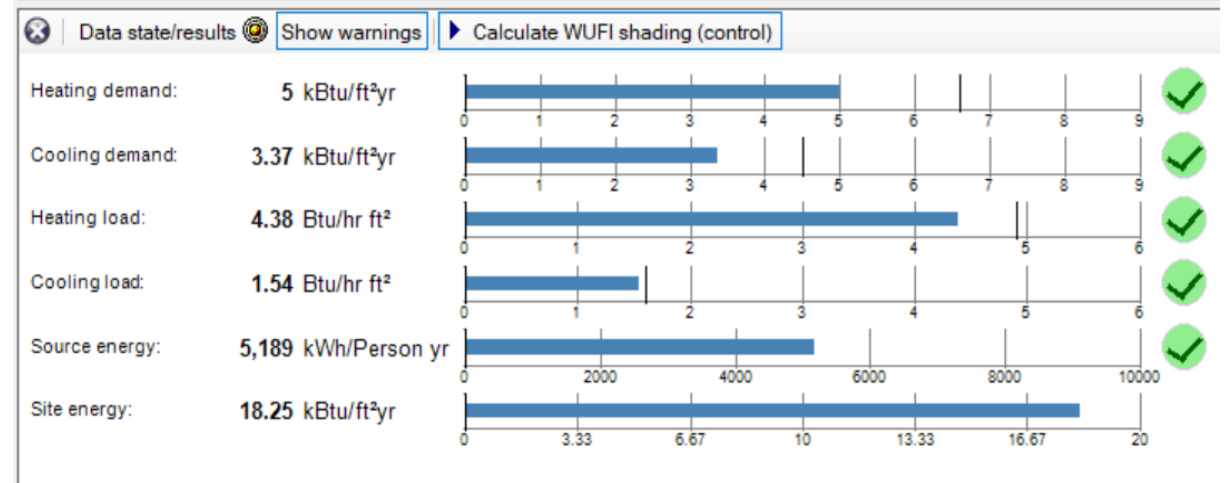

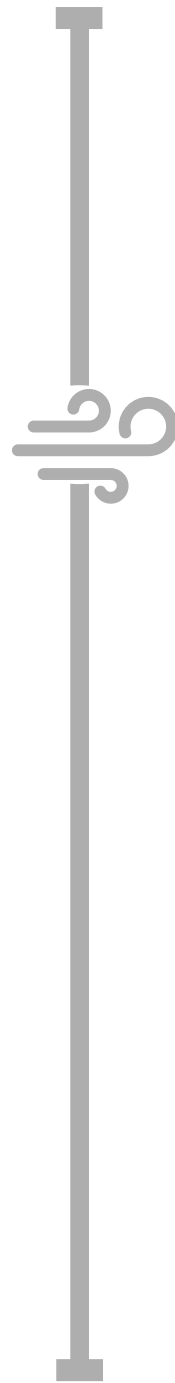
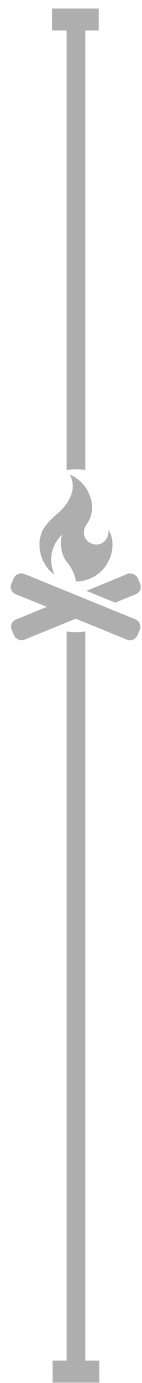
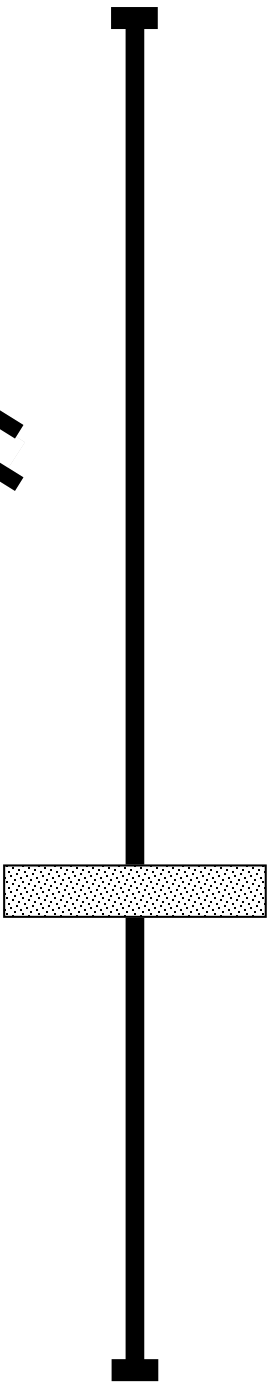
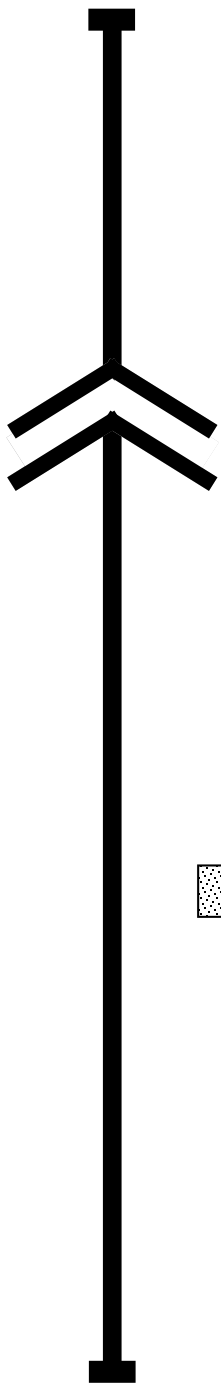
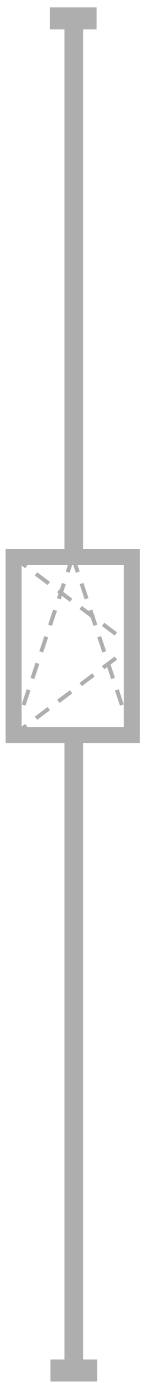

# Composition

- High Performance Envelope
- Slab-on-Grade R-6.7
  - Polyiso Insulation
- Conventional Wood Framing R-47
  - Flash & Batt with Continuous
- Roof/Ceiling (Pitched & Flat) R-86/55
  - Blown-in Cellulose
  - Polyiso (Flat Roofs)

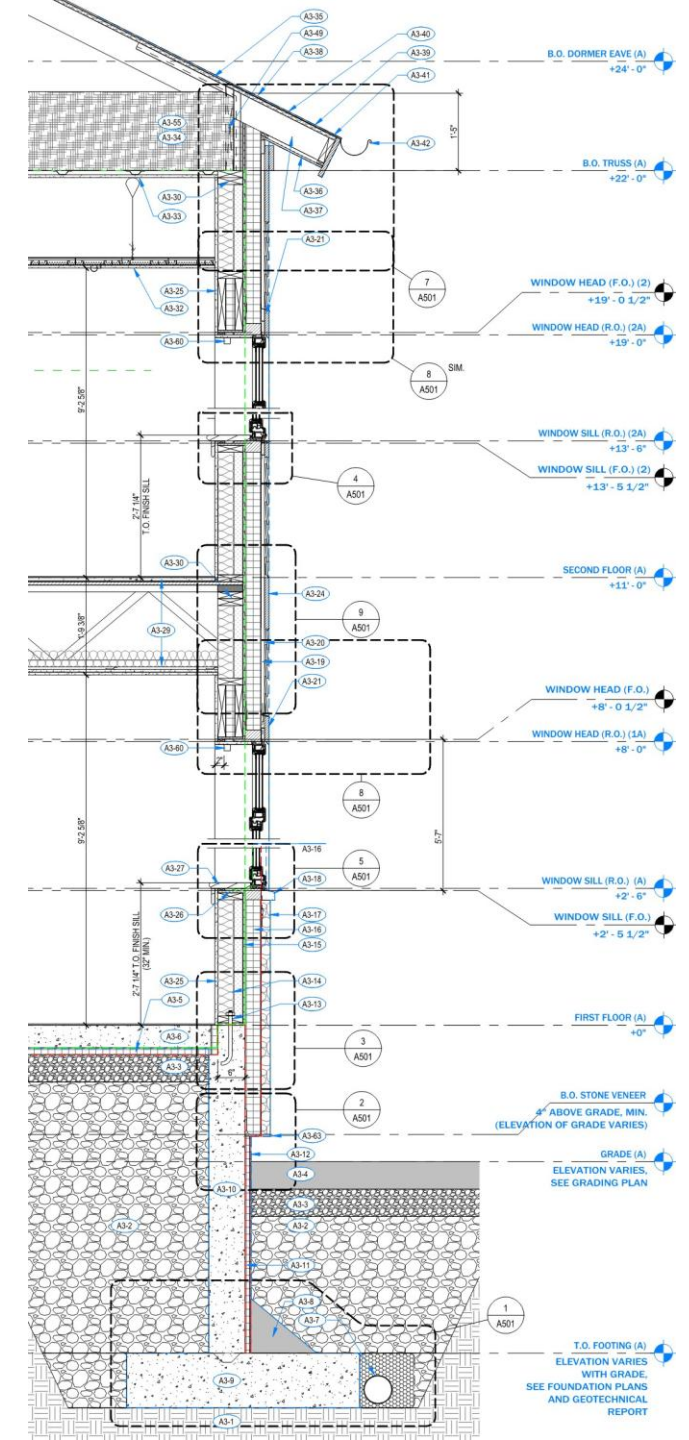
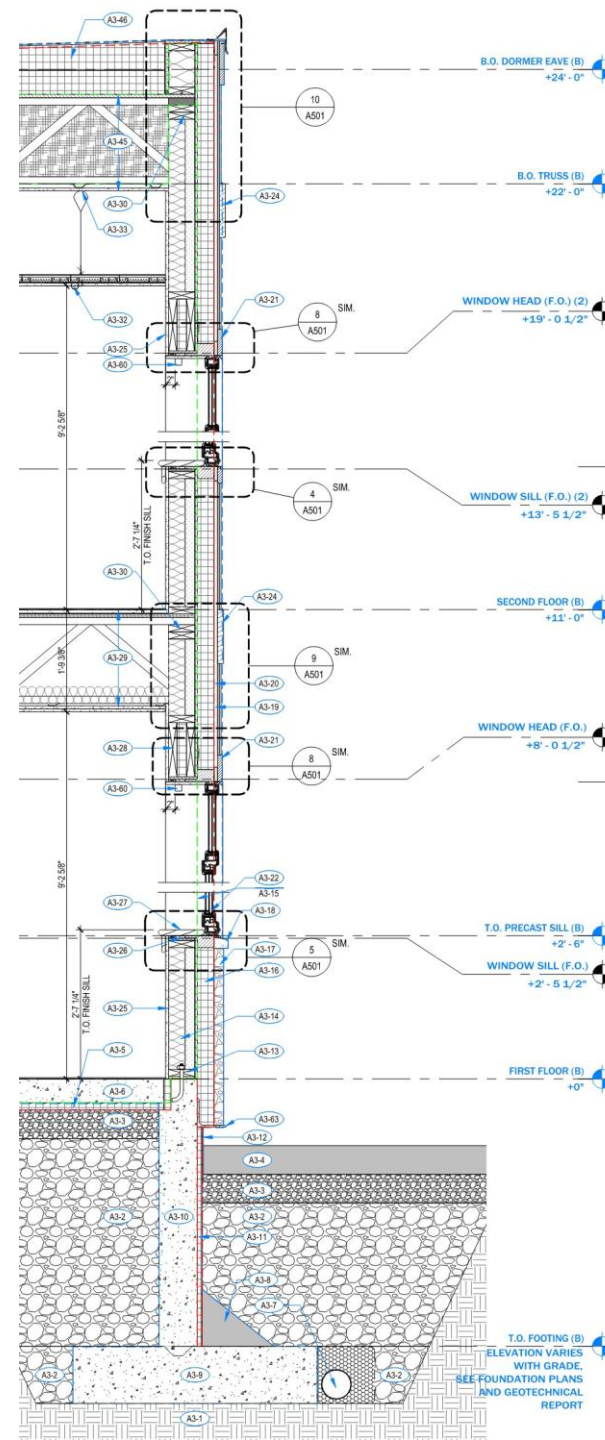

# The Notes

- Pencil Test
  - Air/Vapor Control
  - Water Control
  - Thermal Control
- Devil in the Details
  - Slab Edge
  - Sills, Heads, Jambs
  - Floor/Ceiling to Wall
  - Eaves & Soffits

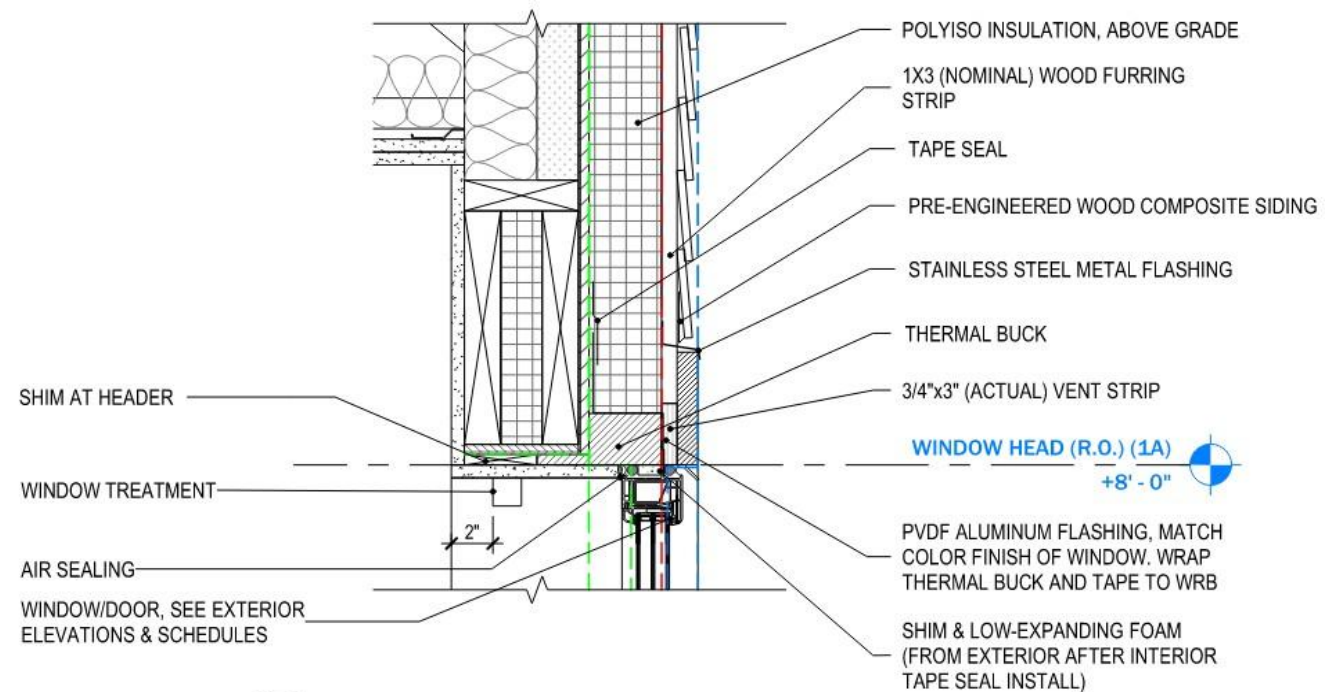

8 TYPICAL WINDOW HEAD DETAIL  
1 1/2" = 1'-0"

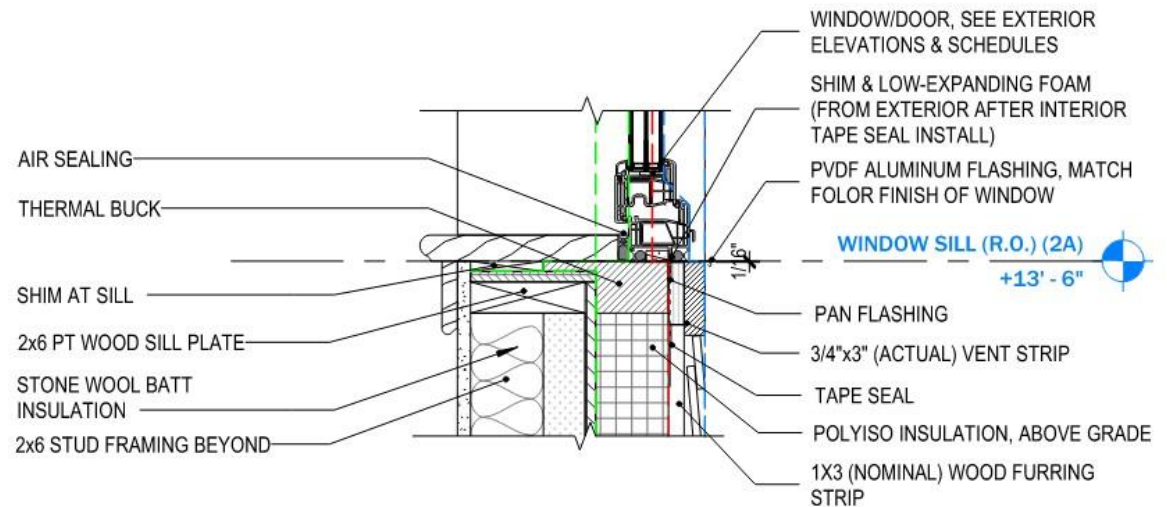

4 TYPICAL WINDOW SILL DETAIL  
1 1/2" = 1'-0"

# Challenges

- Structural Design
- Thermal Bridges
- Awnings & Canopies
- Patios & Balconies

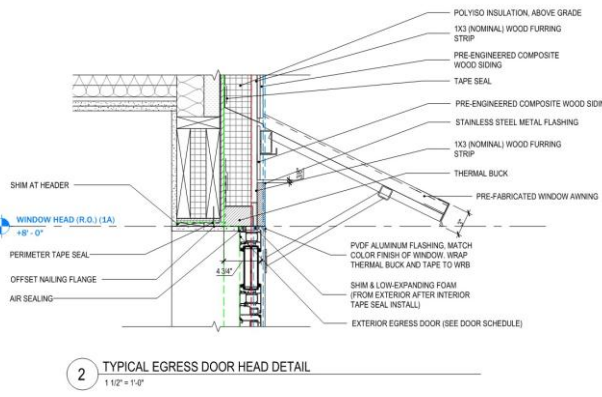
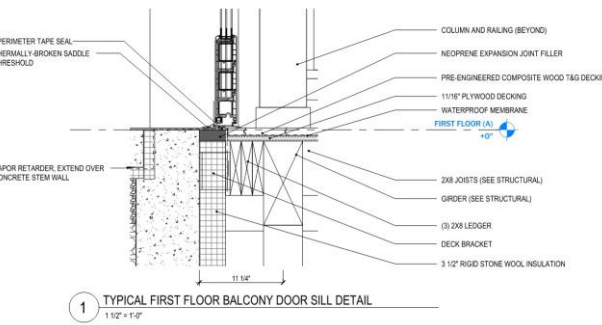
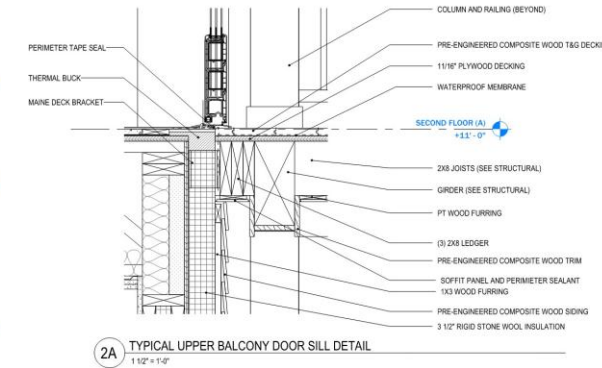
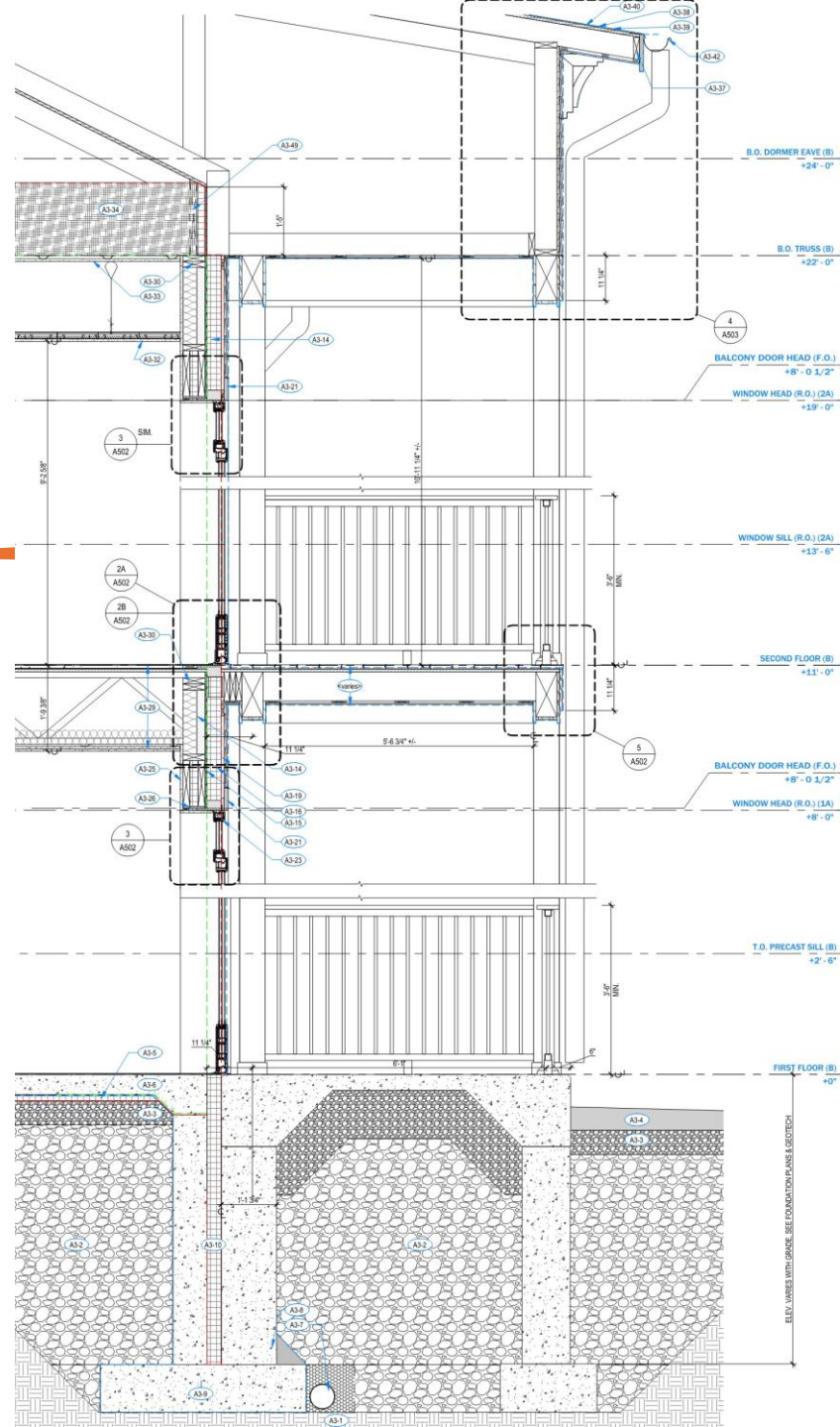



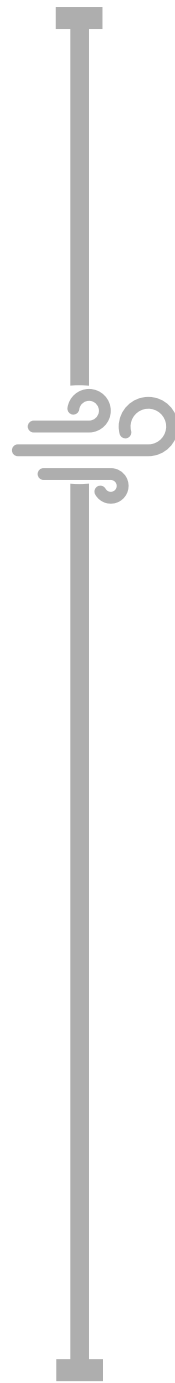
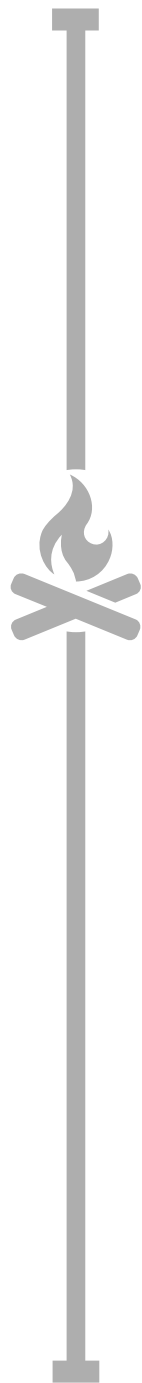
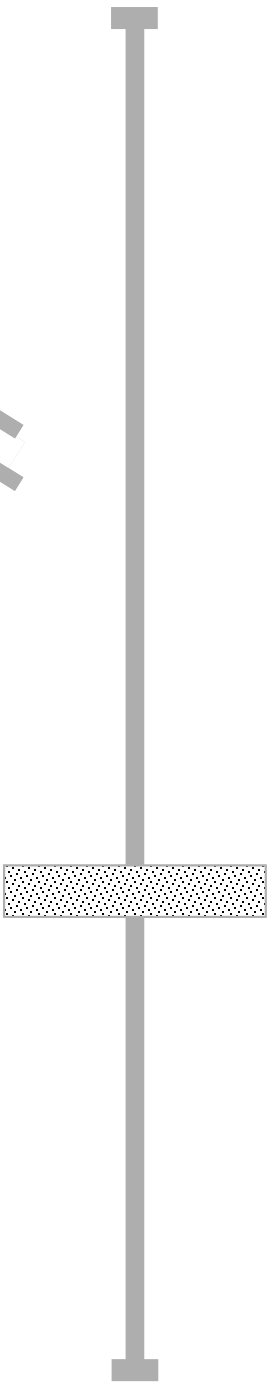
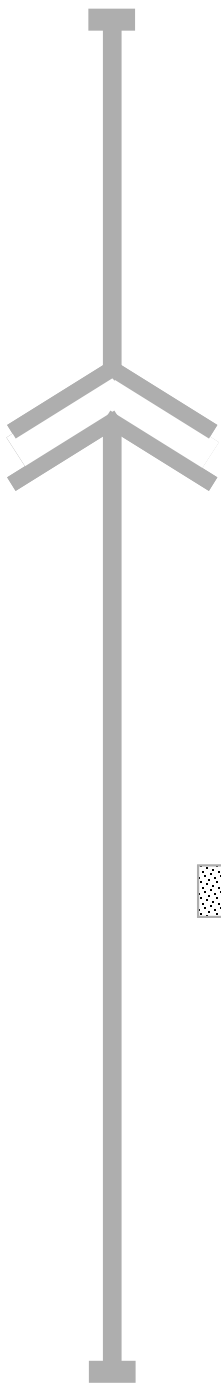
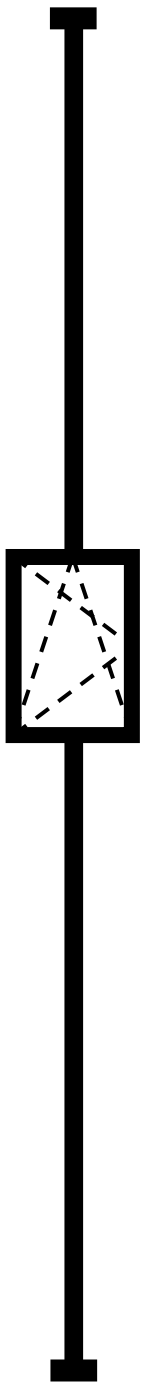

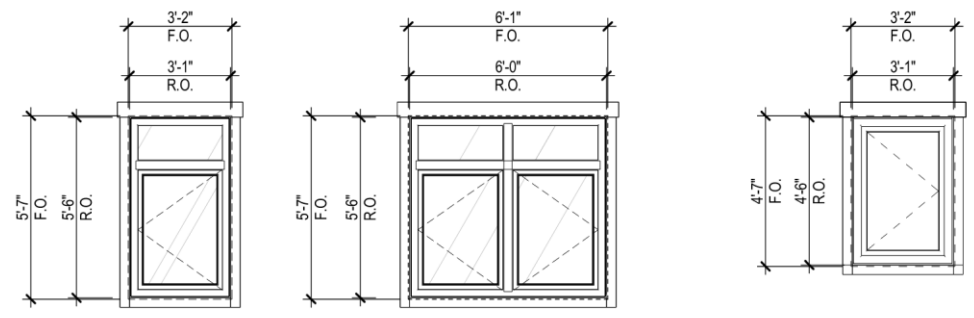
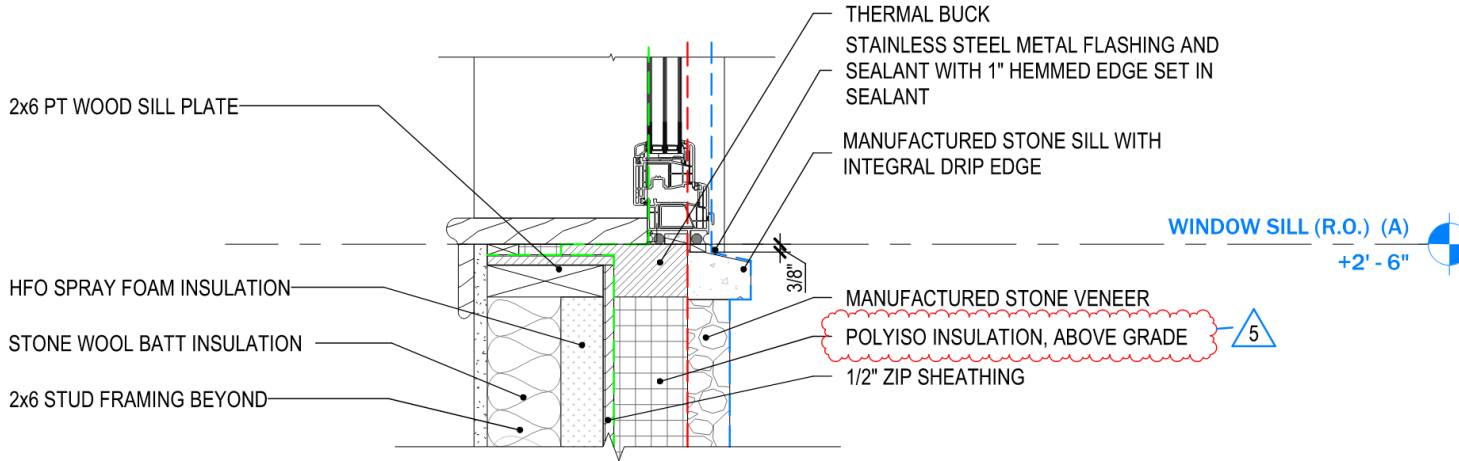

W1 W2 W3

**5** TYPICAL WINDOW SILL DETAIL AT MASONRY STRING COURSE  
 1 1/2" = 1'-0"

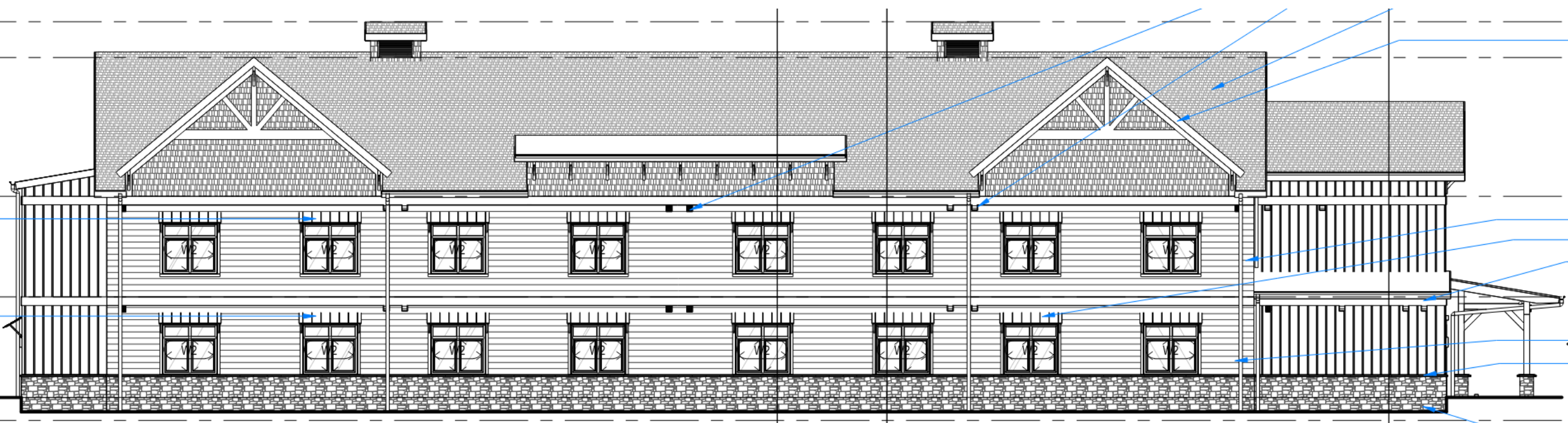



**Phius Product Number:** W-101226  
**Date Last Certified:** 08/15/2023  
**THERM Files Available:** Yes

**Phius Certification Path:** Orange Path  
**Valid Through:** 08/15/2025  
**Air Leakage Test Data Available:** No



**PRODUCT INFORMATION**

<b>Product Name:</b> Intus Supera CW Fixed	
<b>Manufacturer:</b> Intus Windows	<b>Primary Frame Material:</b> Vinyl
<b>Series:</b> Supera	<b>Fixed or Operable:</b> Fixed
<b>Model:</b> Supera CW Fixed	<b>Operation Type:</b> Fixed

**IGU DETAILS**

<b>Glazing Name:</b> SN51_28_4x18Arx4x18ArxCG4		
<b>Glass Layers:</b> Triple	<b>Gas Fill:</b> Argon	<b>Spacer:</b> SWISSPACER ULTIMATE

**RECOMMENDED CLIMATE ZONES** (NOTE: This information is not for use in building energy models. See next section.)

**Recommended Climate Zones and Whole-Window U-values by Zone, at Standard Model Size [Btu/hr·ft²·°F]**

Climate Zone	0, 1, 2	3A	3B	3C	4A, 4B	4C, 5C	5A, 5B	6	7	8
Recommended Zones	✓	✓	✓	✓	✓	✓	✓	✓		
U-Whole-Window	0.12	0.12	0.12	0.12	0.12	0.12	0.13	0.13	0.14	0.14
<b>Modeled Size [W×H]</b>	47.24" × 59.06"		<b>SHGC, Whole Window:</b> 0.19				<b>Condensation Resistance:</b>			

**COMPONENT-LEVEL PERFORMANCE DATA [IP Units] | Compatible with building energy modeling tools**

**U-COG | Center of Glass U-Values, by Climate Zone [Btu/hr·ft²·°F]**

Climate Zone	0, 1, 2	3A	3B	3C	4A, 4B	4C, 5C	5A, 5B	6	7	8
U-COG Value	0.09	0.09	0.09	0.09	0.09	0.09	0.10	0.10	0.11	0.11

**SHGC-COG | Center of Glass Solar Heat Gain Coefficient, All Climate Zones** 0.23

Frame Parameters	Left Jamb	Right Jamb	Head	Sill
Frame Section	Left	Right	Top	Bottom
Frame Width	2.60"	2.60"	2.60"	2.60"
Frame U-Value [Btu/hr·ft²·°F]	0.20	0.20	0.21	0.21
Glazing-to-Frame Psi Value [Btu/hr·ft·°F]	0.0108	0.0108	0.0105	0.0105

**Frame-to-Wall Psi Value** is dependent on the on-site installation condition. (See Phius Guidebook for more details.)



**Phius Product Number:** W-101221  
**Date Last Certified:** 08/15/2023  
**THERM Files Available:** Yes

**Phius Certification Path:** Orange Path  
**Valid Through:** 08/15/2025  
**Air Leakage Test Data Available:** No



**PRODUCT INFORMATION**

<b>Product Name:</b> Intus Supera CW Casement	
<b>Manufacturer:</b> Intus Windows	<b>Primary Frame Material:</b> Vinyl
<b>Series:</b> Supera CW	<b>Fixed or Operable:</b> Operable
<b>Model:</b> Supera CW Casement	<b>Operation Type:</b> Casement

**IGU DETAILS**

<b>Glazing Name:</b> SN51_28_4x18Arx4x18ArxCG4		
<b>Glass Layers:</b> Triple	<b>Gas Fill:</b> Argon	<b>Spacer:</b> SWISSPACER ULTIMATE

**RECOMMENDED CLIMATE ZONES** (NOTE: This information is not for use in building energy models. See next section.)

**Recommended Climate Zones and Whole-Window U-values by Zone, at Standard Model Size [Btu/hr·ft²·°F]**

Climate Zone	0, 1, 2	3A	3B	3C	4A, 4B	4C, 5C	5A, 5B	6	7	8
Recommended Zones	✓	✓	✓	✓	✓	✓				
U-Whole-Window	0.17	0.17	0.17	0.17	0.17	0.17	0.17	0.17	0.18	0.18
<b>Modeled Size [W×H]</b>	23.62" × 59.06"		<b>SHGC, Whole Window:</b> 0.12				<b>Condensation Resistance:</b>			

**COMPONENT-LEVEL PERFORMANCE DATA [IP Units] | Compatible with building energy modeling tools**

**U-COG | Center of Glass U-Values, by Climate Zone [Btu/hr·ft²·°F]**

Climate Zone	0, 1, 2	3A	3B	3C	4A, 4B	4C, 5C	5A, 5B	6	7	8
U-COG Value	0.09	0.09	0.09	0.09	0.09	0.09	0.10	0.10	0.11	0.11

**SHGC-COG | Center of Glass Solar Heat Gain Coefficient, All Climate Zones** 0.23

Frame Parameters	Left Jamb	Right Jamb	Head	Sill
Frame Section	Left	Right	Top	Bottom
Frame Width	4.57"	4.57"	4.57"	4.57"
Frame U-Value [Btu/hr·ft²·°F]	0.23	0.23	0.23	0.23
Glazing-to-Frame Psi Value [Btu/hr·ft·°F]	0.0101	0.0101	0.0098	0.0098

**Frame-to-Wall Psi Value** is dependent on the on-site installation condition. (See Phius Guidebook for more details.)

# Entry/Exit Doors

- Passive House Certified
- ADA-Compliant Thresholds
- Commercial Rated for High Traffic

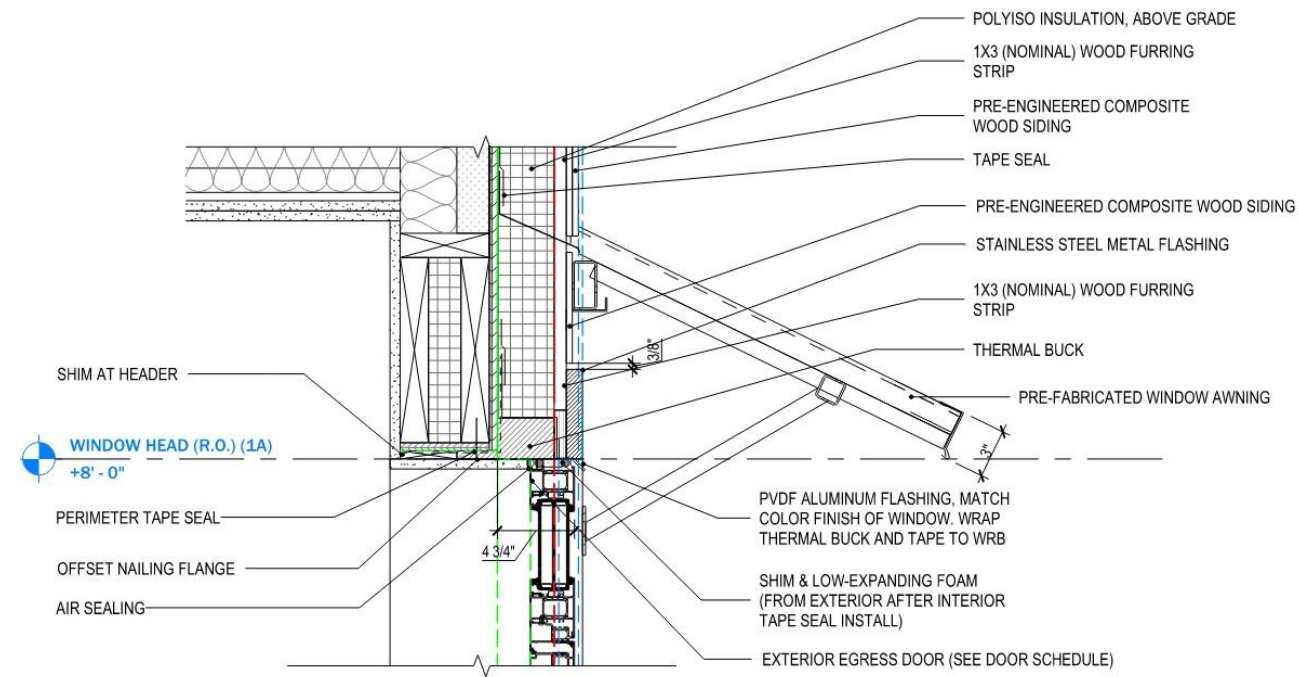

2 TYPICAL EGRESS DOOR HEAD DETAIL  
1 1/2" = 1'-0"

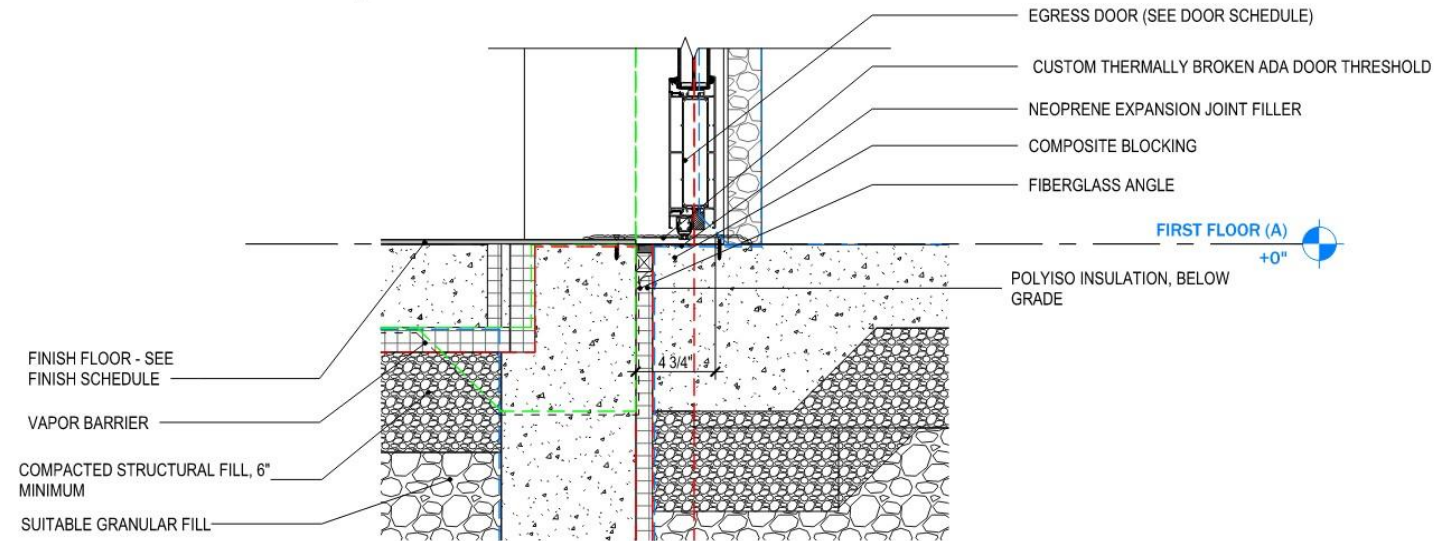

1 TYPICAL EGRESS DOOR SILL  
1 1/2" = 1'-0"

# Climate

<b>phius 2021</b> Custom Performance Criteria Calculator v3.3		
<b>BUILDING FUNCTION</b>	RESIDENTIAL	
<b>Climate Location</b>	TANNERSVILLE, NY   5A	
<b>Envelope Area (sf)</b>	27,858	
<b>iCFA (sf)</b>	16,167	
<b>Dwelling Units (Count)</b>	15	
<b>Total Bedrooms (Count)</b>	15	
Space Conditioning Criteria		
<b>Annual Heating Demand</b>	6.6	kBTU/sf.yr
<b>Annual Cooling Demand</b>	4.5	kBTU/sf.yr
<b>Peak Heating Load</b>	4.9	BTU/sf.hr
<b>Peak Cooling Load</b>	1.6	BTU/sf.hr
Source Energy Criteria		
<b>phius CORE</b>	5,675.0	kWh/person.yr

<b>Phius 2021</b> Performance Criteria Calculator v3.3		
<b>UNITS:</b>	IMPERIAL (IP)	
<b>BUILDING FUNCTION:</b>	RESIDENTIAL	
<b>PROJECT TYPE:</b>	NEW CONSTRUCTION	
<b>STATE/ PROVINCE</b>	MASSACHUSETTS	
<b>CITY</b>	BOSTON LOGAN INT ARF	
<b>Envelope Area (ft²)</b>	27,858.0	
<b>iCFA (ft²)</b>	16,167.0	
<b>Dwelling Units (Count)</b>	15	
<b>Total Bedrooms (Count)</b>	15	
Space Conditioning Criteria		
<b>Annual Heating Demand</b>	5.5	kBtu/ft².yr
<b>Annual Cooling Demand</b>	5.5	kBtu/ft².yr
<b>Peak Heating Load</b>	4.0	Btu/ft².hr
<b>Peak Cooling Load</b>	2.7	Btu/ft².hr
Source Energy Criteria		
<b>Phius CORE</b>	5675	kWh/person.yr
<b>Phius ZERO</b>	0	kWh/person.yr

Data: TANNERSVILLE, NY

Setting	Jan.	Feb.	March	April	May	June	July	Aug.	Sept.	Oct.	Nov.	Dec.	Heating W. 1	Heating W. 2	Cooling W. 1	Cooling W. 2
Temperature [°F]																
Ambient	23	25.34	33.44	45.68	56.66	64.22	69.08	67.46	60.8	49.46	38.48	28.58	7.34	18.14	74.48	
Dew point	14.54	15.44	21.2	31.1	44.24	54.32	58.64	58.1	52.16	40.46	29.12	21.02				
Sky*	-6.88	-5.98	3.02	16.52	31.82	42.8	48.2	47.12	39.38	26.42	13.28	2.48				
Ground*																
Solar radiation [kBtu/ft²Month]													Solar radiation [Btu/hr ft²]			
North	3.8	5.39	8.24	10.78	14.9	16.48	15.85	12.36	9.19	6.97	4.75	3.8	5.07	3.8	20.6	
East	11.09	15.53	21.87	25.68	32.65	32.65	33.92	30.11	25.68	16.8	10.46	8.88	11.41	5.71	44.06	
South	28.85	32.97	34.24	28.21	27.26	25.04	26.31	30.43	33.92	32.33	25.04	25.04	30.43	11.09	33.28	
West	11.09	16.17	22.19	24.41	31.38	30.75	31.38	29.48	24.73	19.34	11.73	10.14	12.05	6.02	41.21	
Global	15.85	23.14	35.19	41.84	53.89	55.16	55.79	50.72	40.26	27.26	16.48	13.63	18.39	10.14	72.28	

\* Optional input, Sky/Ground: if not defined, temperatures will be estimated)

Data: BOSTON LOGAN INT ARPT MA

Setting	Jan.	Feb.	March	April	May	June	July	Aug.	Sept.	Oct.	Nov.	Dec.	Heating W. 1	Heating W. 2	Cooling W. 1	Cooling W. 2
Temperature [°F]																
Ambient	26.6	31.1	38.84	47.48	58.82	66.02	74.12	71.06	64.58	53.96	43.34	35.96	16.88	31.64	83.48	
Dew point	13.82	17.42	24.62	35.06	47.12	54.14	60.62	60.98	53.24	41.72	33.44	23				
Sky*	-6.52	-1.66	8.6	21.38	35.78	45.86	51.98	51.26	42.44	29.3	18.32	8.96				
Ground*																
Solar radiation [kBtu/ft²Month]													Solar radiation [Btu/hr ft²]			
North	7.61	10.78	12.36	12.68	16.17	16.8	18.07	14.9	11.09	8.56	6.02	6.02	12.05	7.92	27.58	
East	14.9	19.34	25.36	25.99	30.43	28.21	32.33	29.16	25.68	19.34	12.36	11.73	22.82	13.31	61.5	
South	32.97	36.14	34.87	27.58	27.26	23.77	27.58	31.38	33.92	35.19	29.8	30.75	49.45	27.26	41.84	
West	13.95	19.65	22.82	25.04	29.8	31.07	32.65	29.16	24.09	18.7	13.63	13	22.19	11.41	53.26	
Global	17.75	24.73	35.5	42.79	54.84	54.84	59.6	52.62	40.58	29.16	19.02	14.9	26.94	16.48	101.44	

\* Optional input, Sky/Ground: if not defined, temperatures will be estimated)

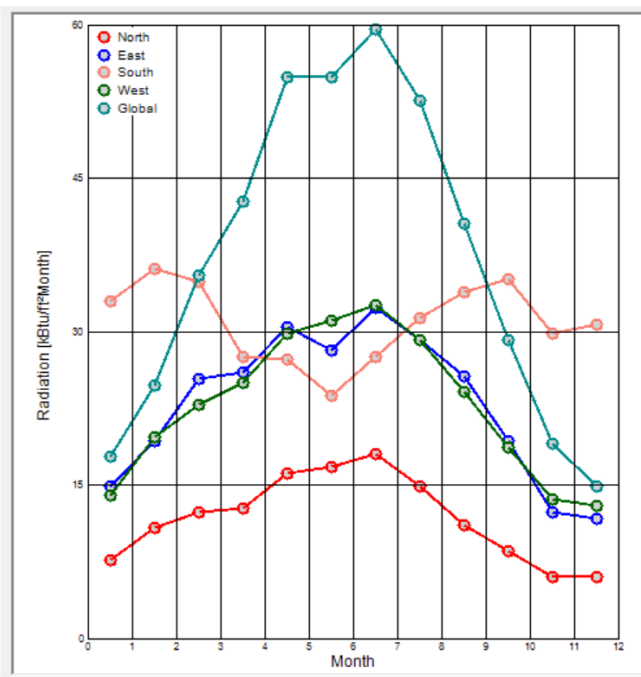
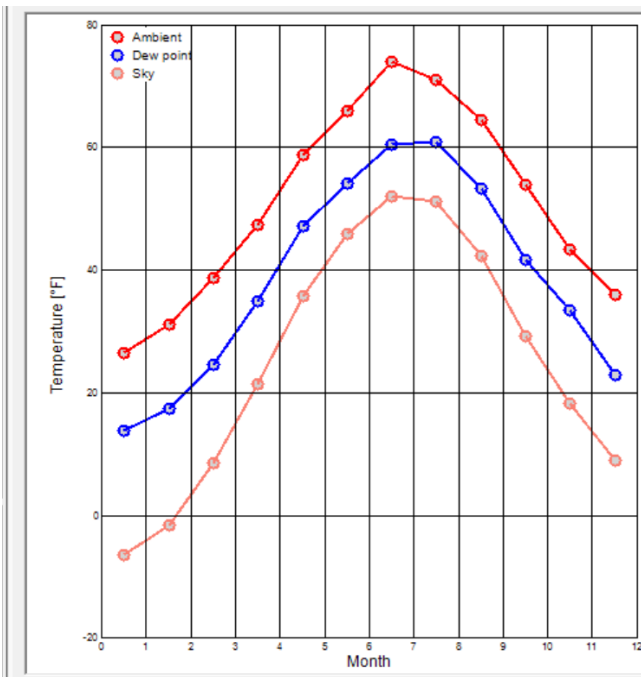
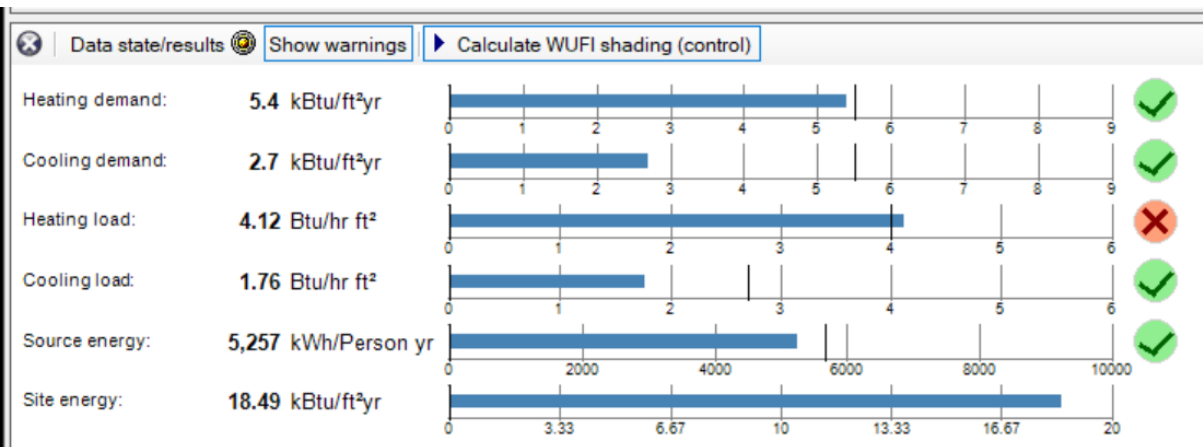
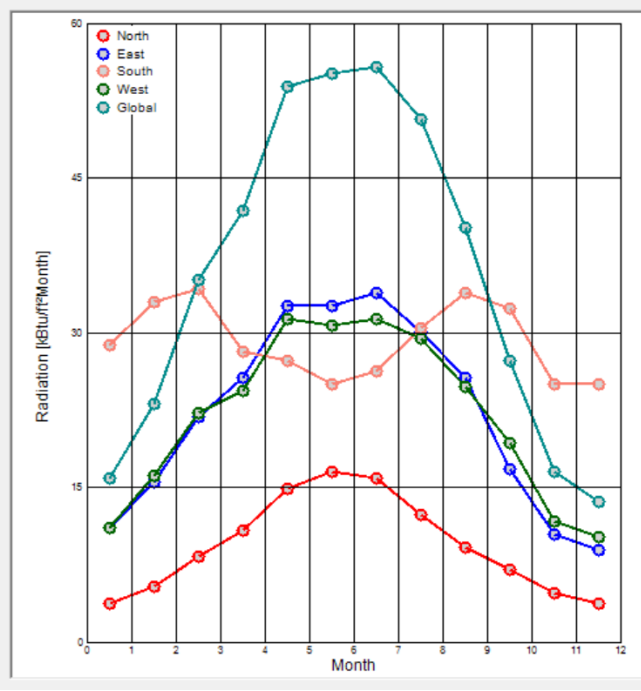
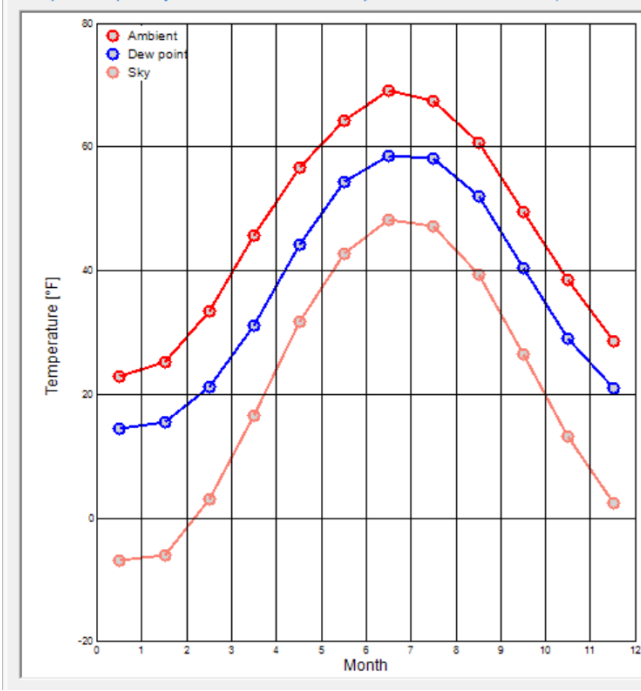
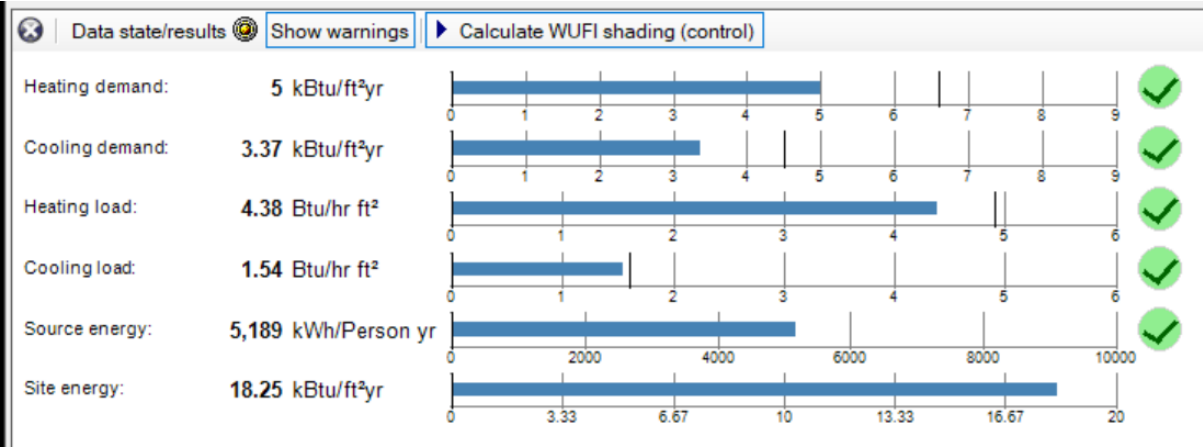

# Internal Gains V. Climate

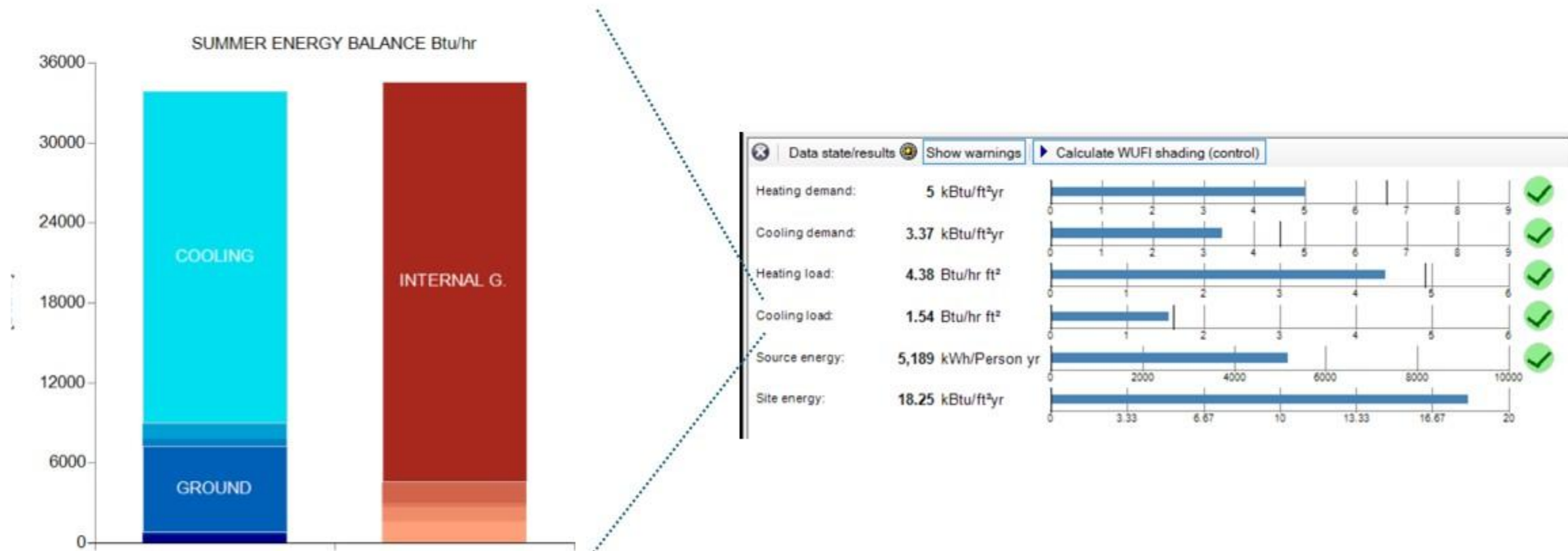



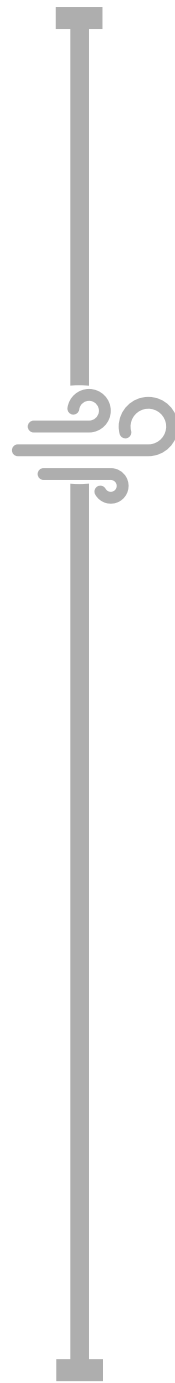
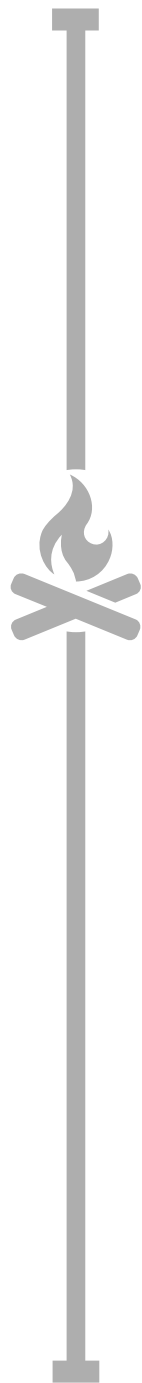
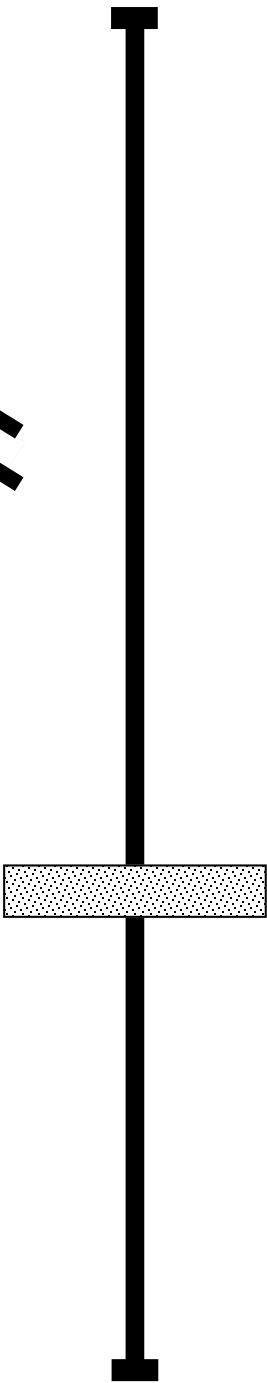
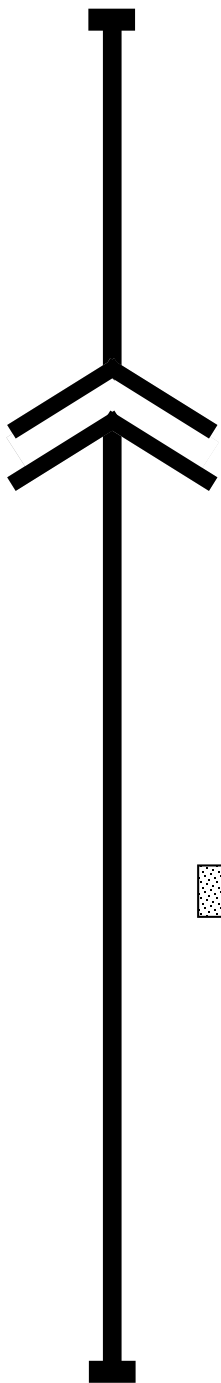
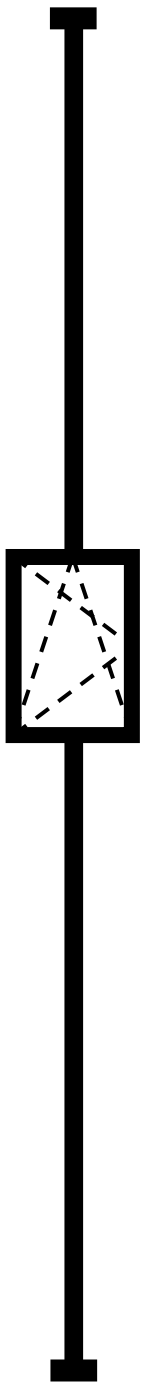

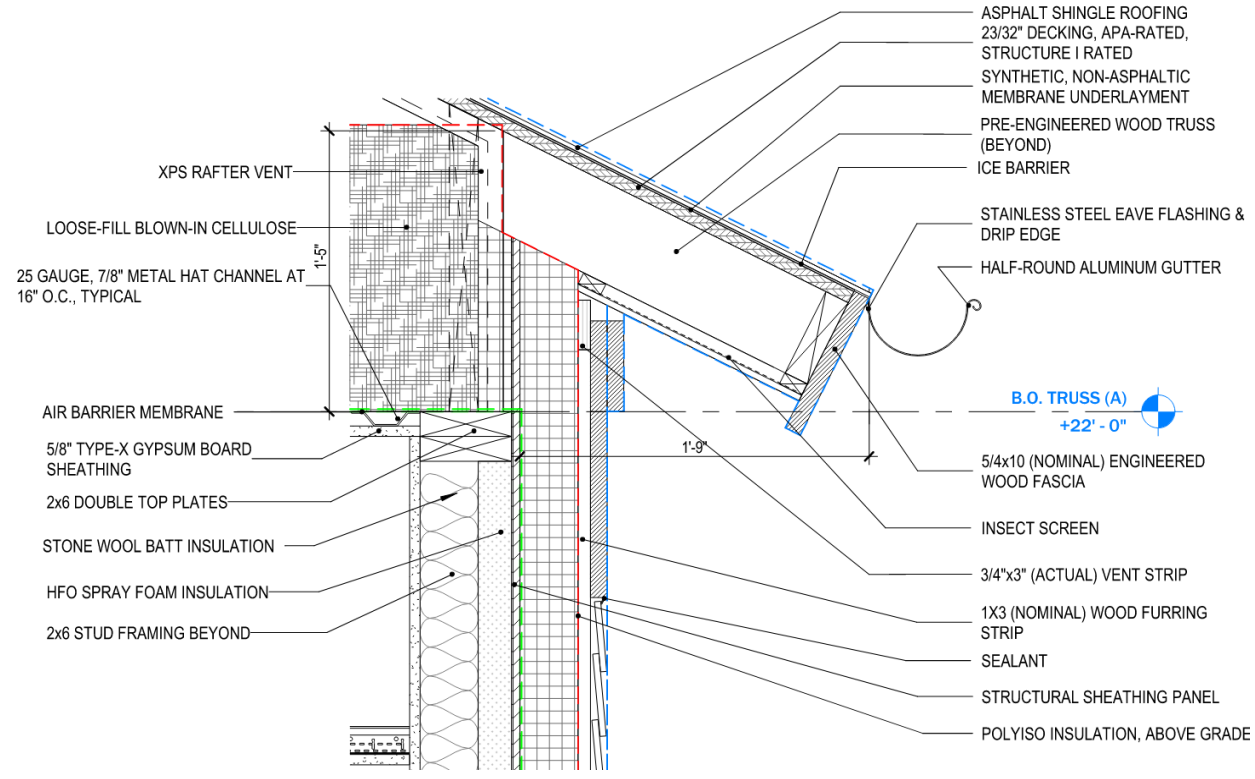
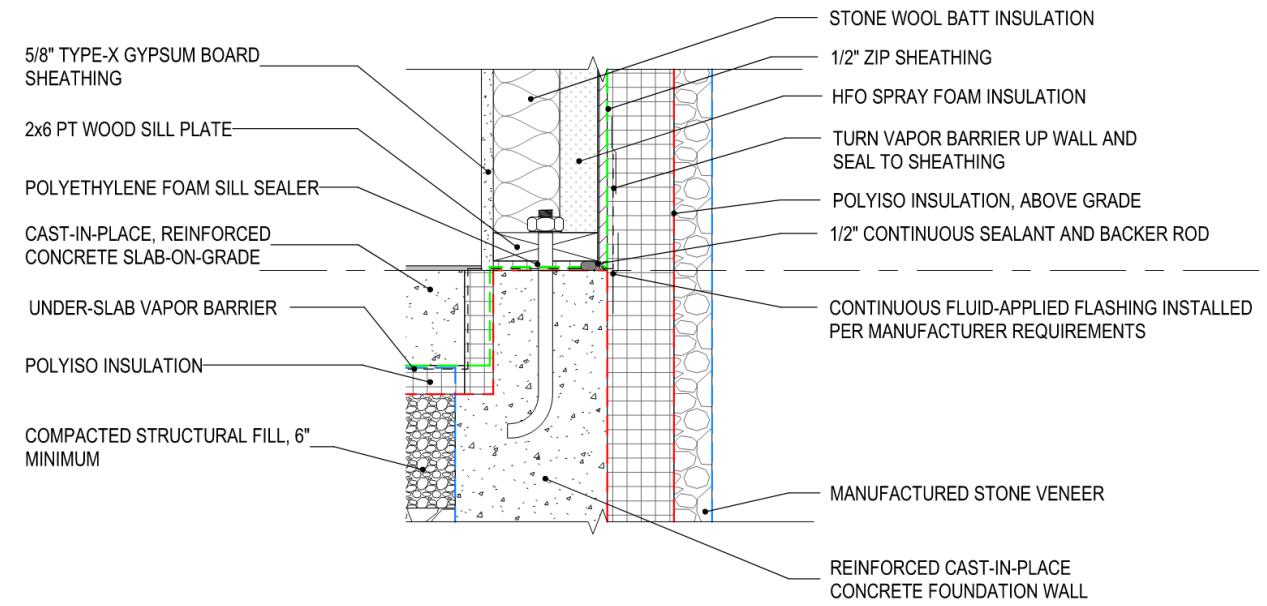

# Window Properties

## Basic data

Uw -mounted	[Btu/hr ft <sup>2</sup> °F]	0.1755
Frame factor		0.6815
Glass U-value	[Btu/hr ft <sup>2</sup> °F]	0.1
SHGC/Solar energy transmittance (perpendicular)		0.392

## Frame data

Data state/results Show warnings Calculate WUFI shading (control)

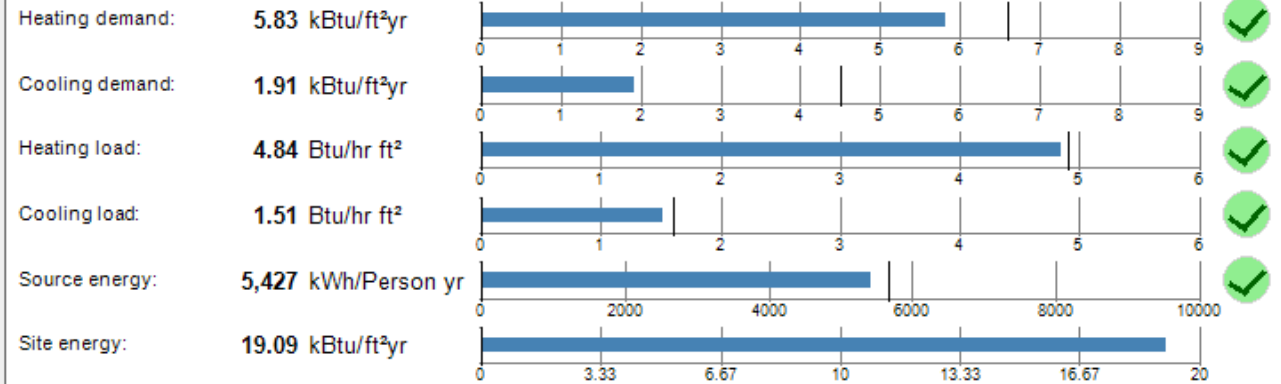

## Basic data

Uw -mounted	[Btu/hr ft <sup>2</sup> °F]	0.1667
Frame factor		0.684
Glass U-value	[Btu/hr ft <sup>2</sup> °F]	0.1
SHGC/Solar energy transmittance (perpendicular)		0.23

Data state/results Show warnings Calculate WUFI shading (control)

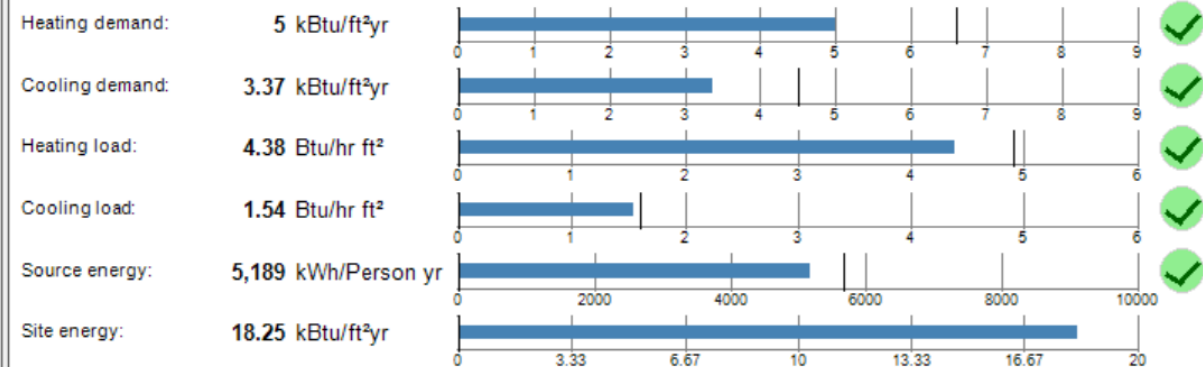

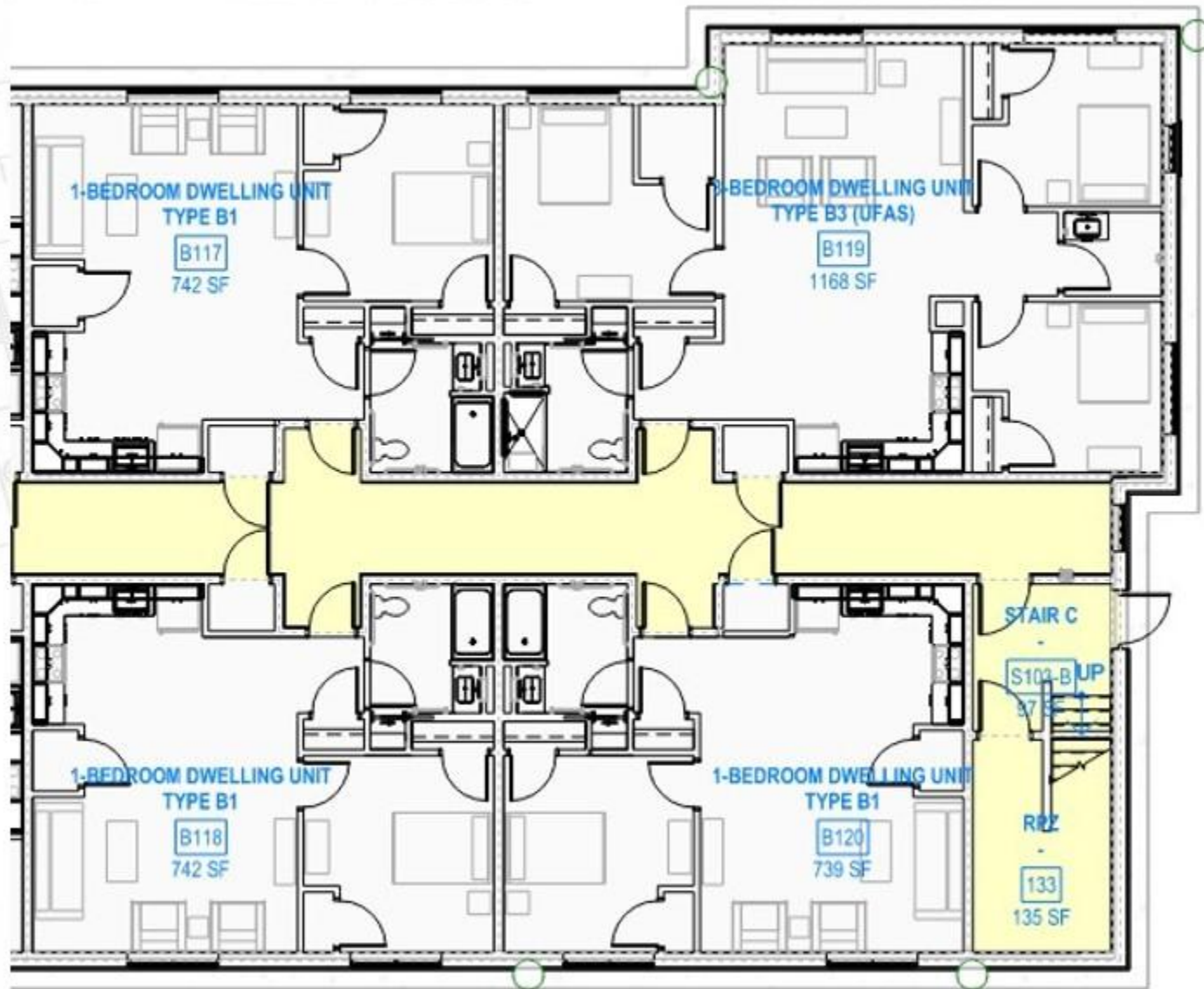

# Constructability

- Programming:
  - Floor Plans
  - Dwelling Unit Types
  - Plumbing Stacks
- Simple Forms
  - Exterior Diaphragm
  - Demising Walls
  - Minimize Shear
- Conventional Design





- Nicole Schuster, AIA, CPHC, LEED AP, [Nicole@positive-trace.com](mailto:Nicole@positive-trace.com)
- Andrew Van Roo, [vanroo@ashleymcgraw.com](mailto:vanroo@ashleymcgraw.com)

# KEYNOTES

FOR REFERENCE

KEYNOTES - WALL SECTIONS	
NOTE: NOT ALL KEYNOTES MAY BE REFERENCED	
NO.	DESCRIPTION
A3-1	SUITABLE UNDISTURBED NATIVE SOIL -OR- SUITABLE GRANULAR FILL, REFER TO STRUCTURAL AND GEOTECHNICAL REPORT.
A3-2	SUITABLE GRANULAR FILL, REFER TO STRUCTURAL AND GEOTECHNICAL REPORT.
A3-3	MINIMUM 6" COMPACTED STRUCTURAL FILL, REFER TO STRUCTURAL.
A3-4	GRADE (TOPSOIL/SEED), REFER TO CIVIL.
A3-5	R-10 (1.5") POLYISO INSULATION AT UNDERSIDE OF SLAB IN IT'S ENTIRETY, U.N.O.. R-10 (1-1/2") POLYISO INSULATION AT SLAB EDGE, ENTIRE PERIMETER OF SLAB.
A3-6	REINFORCED CONCRETE SLAB-ON-GRADE, REFER TO STRUCTURAL. INSTALL 15-MIL POLYOLEFIN VAPOR RETARDER WITH JOINTS LAPPED NOT LESS THAN 6" AT UNDERSIDE OF ENTIRE SLAB.
A3-7	RIGID PERFORATED DRAIN PIPE AT ENTIRE PERIMETER OF BUILDING, REFER TO CIVIL. INSTALL 6" MIN., OF STONE DRAINAGE BED AROUND PIPE AND WRAP WITH GEOTEXTILE FILTER FABRIC. TIE-IN ROOF DRAINS, REFER TO PLUMBING.
A3-8	FIBERGLASS CANT.
A3-9	REINFORCED CAST-IN-PLACE CONCRETE FOOTING, REFER TO STRUCTURAL.
A3-10	REINFORCED CAST-IN-PLACE FOUNDATION WALL, REFER TO STRUCTURAL.
A3-11	BUILDING A & B: R-6 (1") POLYISO INSULATION. BUILDING C: R-15.3 (2.3") POLYISO INSULATION. SUITABLE FOR BELOW GRADE APPLICATION, EXTEND FROM FOOTING UP TIGHT TO UNDERSIDE FRP ANGLE.
A3-12	1/4" XPS PROTECTION BOARD. TROWEL ON PROTECTIVE,
A3-13	2X P.T. WOOD SILL PLATE OVER POLYETHYLENE FOAM SILL SEALER. FASTEN SILL PLATE TO FOUNDATION WALL WITH GALVANIZED ANCHOR BOLTS, REFER TO STRUCTURAL.
A3-14	2X6 WOOD FRAMING (BEYOND), REFER TO STRUCTURAL. FILL THE ENTIRE STUD CAVITY WITH R-14.4 (2") HFO SPRAY FOAM INSULATION & R-15 (3-1/2") STONE WOOL BATT INSULATION.
A3-15	1/2" ENGINEERED STRUCTURAL SHEATHING PANEL WITH INTEGRAL WEATHER-RESISTANT BARRIER, TAPE ALL SEAMS.
A3-16	R-21.7 (3-1/2") POLYISO INSULATION, ABOVE GRADE.
A3-17	MANUFACTURED STONE VENEER.
A3-18	PRE-FORMED MANUFACTURED STONE SILL.
A3-19	1X3 P.T. SOLID WOOD FURRING STRIPS AT 16" O.C. VERTICALLY (BEYOND).
A3-20	0.315" THICK, ENGINEERED WOOD COMPOSITE SIDING, FACTORY PRIMED AND PREFINISHED CEDAR TEXTURE, INSTALL PER MANUFACTURER'S REQUIREMENTS. SEE EXTERIOR ELEVATIONS FOR ADDITIONAL INFORMATION
A3-21	5/4 (NOMINAL), ENGINEERED WOOD TRIM, FACTORY PRIMED AND PREFINISHED CEDAR TEXTURE, INSTALL PER MANUFACTURER'S REQUIREMENTS. SEE EXTERIOR ELEVATIONS FOR ADDITIONAL INFORMATION.
A3-22	POLYMER STEEL REINFORCED WINDOW ASSEMBLY WITH FULLY SIMULATED DIVIDED LITES, SEE EXTERIOR ELEVATIONS & WINDOW SCHEDULE.
A3-24	5/4X12 (NOMINAL), ENGINEERED WOOD BAND TRIM, FACTORY PRIMED AND PREFINISHED CEDAR TEXTURE, INSTALL PER MANUFACTURER'S REQUIREMENTS. SEE EXTERIOR ELEVATIONS FOR ADDITIONAL INFORMATION
A3-25	5/8" TYPE-X GYPSUM BOARD SHEATHING, PREP, PRIME, AND PAINT, REFER TO FINISH SCHEDULE.
A3-26	1/2" PLYWOOD BLOCKING OVER 2X SOLID WOOD SILL PLATE AND 2X SOLID WOOD JAMB/HEAD BLOCKING, ENTIRE PERIMETER OF OPENING.

A3-27	5/4X8 (NOMINAL) SOLID POPLAR SILL AND 1X4 (NOMINAL SOLID POPLAR APRON, PREP, PRIME, AND PAINT. ALL OUTSIDE CORNERS SHOULD BE EASED 1/8" RADIUS.
A3-28	HEADER WITH INSULATION, SEE STRUCTURAL.
A3-29	FLOOR/CEILING ASSEMBLY TYPE F1, SEE FLOOR/CEILING TYPE SCHEDULE.
A3-30	DOUBLE 2X WOOD TOP PLATES
A3-31	ROOF ASSEMBLY TYPE R2, SEE ROOF/CEILING TYPE SCHEDULE.
A3-32	5/8" TYPE-X GYPSUM BOARD, SUSPENDED CEILING SYSTEM, PREP, PRIME, & PAINT.
A3-33	5/8" TYPE-X GYPSUM BOARD SHEATHING ON 7/8" METAL HAT CHANNELS AT 16" O.C.
A3-34	R-88 (24") LOOSE-FILL, BLOWN-IN INSULATION. AT UNDERSIDE OF ROOF TRUSSES: INSTALL POLYETHYLENE AIR BARRIER WITH INTEGRAL MESH REINFORCEMENT TO ACCOMMODATE BLOWN-IN INSULATION. WRAP WOOD TOP PLATES AND OVERLAP WEATHER-RESISTANT BARRIER AT EXTERIOR WALL.
A3-35	ATTIC VENTS (BAFFLES) BETWEEN EACH ROOF TRUSS.
A3-36	0.354" THICK, ENGINEERED WOOD COMPOSITE VENTED SOFFIT PANEL.
A3-37	PRE-ENGINEERED ROOF TRUSSES AT 16" O.C., TO BE DESIGNED BY TRUSS MANUFACTURER.
A3-38	11/16" ROOF DECKING WITH INTEGRAL WEATHER-RESISTANT BARRIER, APA-RATED, EXPOSURE I, WITH CLIPS. TAPE ALL SEAMS.
A3-39	SELF-ADHERING POLYMER MODIFIED BITUMEN SHEETING TO COMPLY WITH ASTM D1970. AT ALL EAVES: INSTALL ICE BARRIER EQUAL TO (2) LAYERS OF 36" WIDE SELF-ADHERING POLYMER MODIFIED BITUMEN SHEETING.
A3-40	ASPHALT SHINGLE ROOFING. AT GABLE ROOF RIDGE: INSTALL RIDGE CAP SHINGLES OVER RIDGE VENT.
A3-41	0.032" THICK ALUMINUM EAVE FLASHING/DRIP.
A3-42	0.032" THICK ALUMINUM, HALF-ROUND GUTTER & ASSOCIATED MOUNTING SUPPORTS. ALL MINIMUM DOWNSPOUTS SHALL TIE-INTO FOUNDATION DRAINS.
A3-43	5/4X10 (NOMINAL), ENGINEERED WOOD FASCIA, FACTORY PRIMED AND PREFINISHED CEDAR TEXTURE, INSTALL PER MANUFACTURER'S REQUIREMENTS.
A3-45	ROOF/CEILING ASSEMBLY TYPE R3, SEE ROOF/CEILING TYPE SCHEDULE. FILL ENTIRE CAVITY WITH LOOSE FILL BLOWN-IN CELLULOSE INSULATION R-60, MIN.
A3-46	R-53.6 (9") POLYISO ROOF INSULATION WITH TAPERED COVER BOARD, SLOPE 1/4" PER FOOT TOWARDS ROOF DRAINS.
A3-47	FULLY ADHERED, 60 MIL MEMBRANE ROOFING, WRAP OVER TOP OF ROOF EDGE FRAMING.
A3-49	1-3/4"X20" MICROLAM LVL BETWEEN EVERY OTHER TRUSS, REFER TO STRUCTURAL.
A3-50	MANUFACTURED STONE VENEER AND PRE-CAST STONE CAP APPLIED TO CONCRETE PIER PER MANUFACTURER REQUIREMENTS, REFER TO STRUCTURAL
A3-51	8X8 (NOMINAL) PSL WOOD COLUMN, STAIN, REFER TO STRUCTURAL
A3-52	6X8 (NOMINAL) WOOD KICKER, STAIN, REFER TO STRUCTURAL
A3-53	8X18 (NOMINAL) GIRDER, STAIN, REFER TO STRUCTURAL
A3-54	4X12 (NOMINAL) WOOD RAFTERS, STAIN, REFER TO STRUCTURAL
A3-55	ROOF ASSEMBLY TYPE R1, SEE ROOF/CEILING TYPE SCHEDULE.
A3-57	EXTERIOR SLAB ON GRADE, REFER TO CIVIL
A3-58	2X WOOD FRAMING AT 16" O.C.
A3-59	1/2" RESILIENT CHANNEL
A3-60	PROVIDE & INSTALL WINDOW TREATMENT AND ASSOCIATED SOLID THROUGH-WALL BLOCKING, AS REQUIRED, SEE FINISHES.
A3-63	FIBERGLASS SHELF ANGLE, SEE STRUCTURAL