

# **BUILDINGENERGY BOSTON**

---

## **Positive Energy from Positive Change: Achieving High Performance in Affordable Housing**

**Keihly Moore (Studio G Architects)**

**Gabriela Shelburne (Studio G Architects)**

**Andrew Wilkinson (Norian/Siani Engineering)**

**Curated by Emily Mottram (Mottram Architects) and Geoff Gunn (Arup)**

---

**Northeast Sustainable Energy Association (NESEA)**

**February 28, 2022**

# Positive Energy from Positive Change: Achieving High Performance in Affordable Housing



# Learning Objectives

- ❑ **Recognize the benefits of different system approaches** through a comparison of two similar sized affordable housing projects designed to Passive House standards.
- ❑ **Apply communication tools**, derived from lessons learned between architects and engineers, to arrive at the best system selections for the project's domestic hot water and ventilation systems.
- ❑ **Identify specific details for energy modeling** in THERM to guide the best location for insulation and to mitigate thermal bridging and moisture problems.
- ❑ **Get familiar with the challenges of mechanical system locations and deciding if solar thermal fits within the project goals** with review of case studies evaluating the pros and cons of different options.





# 37 Wales

## Project Details:

- Passive House designed
- 20 units – 2,3 bedrooms
- 4.5 stories – 26,600 GSF
- EUI = 14.6 (modeled)
- Finalizing Construction Documents
- 100% affordable @ 30% AMI or less
- Community room
- Supportive Housing Services on site



# 37 Wales

## Factors:

- MOH (DND)/DHCD\* put performance requirements on – above and beyond code
- Maintenance efficiency and durability important with the type of residents they serve
- Operating costs

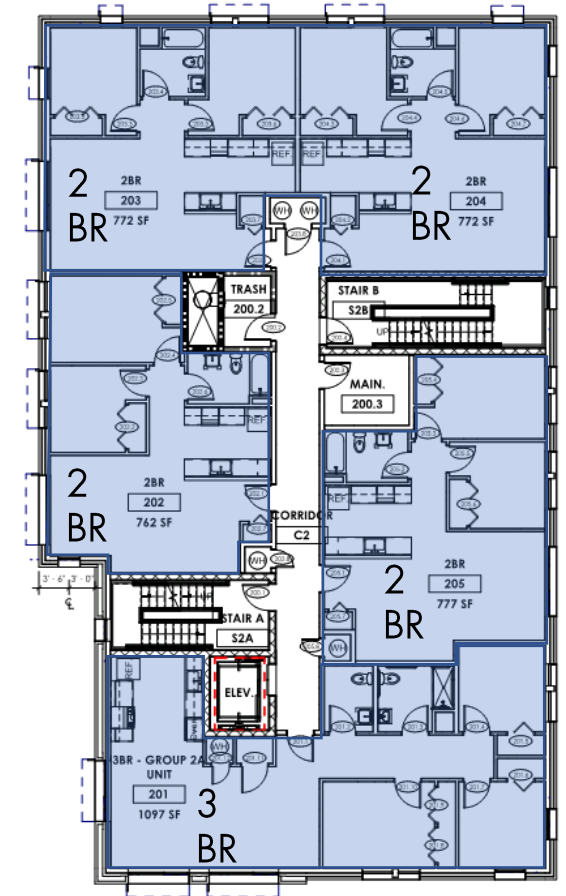
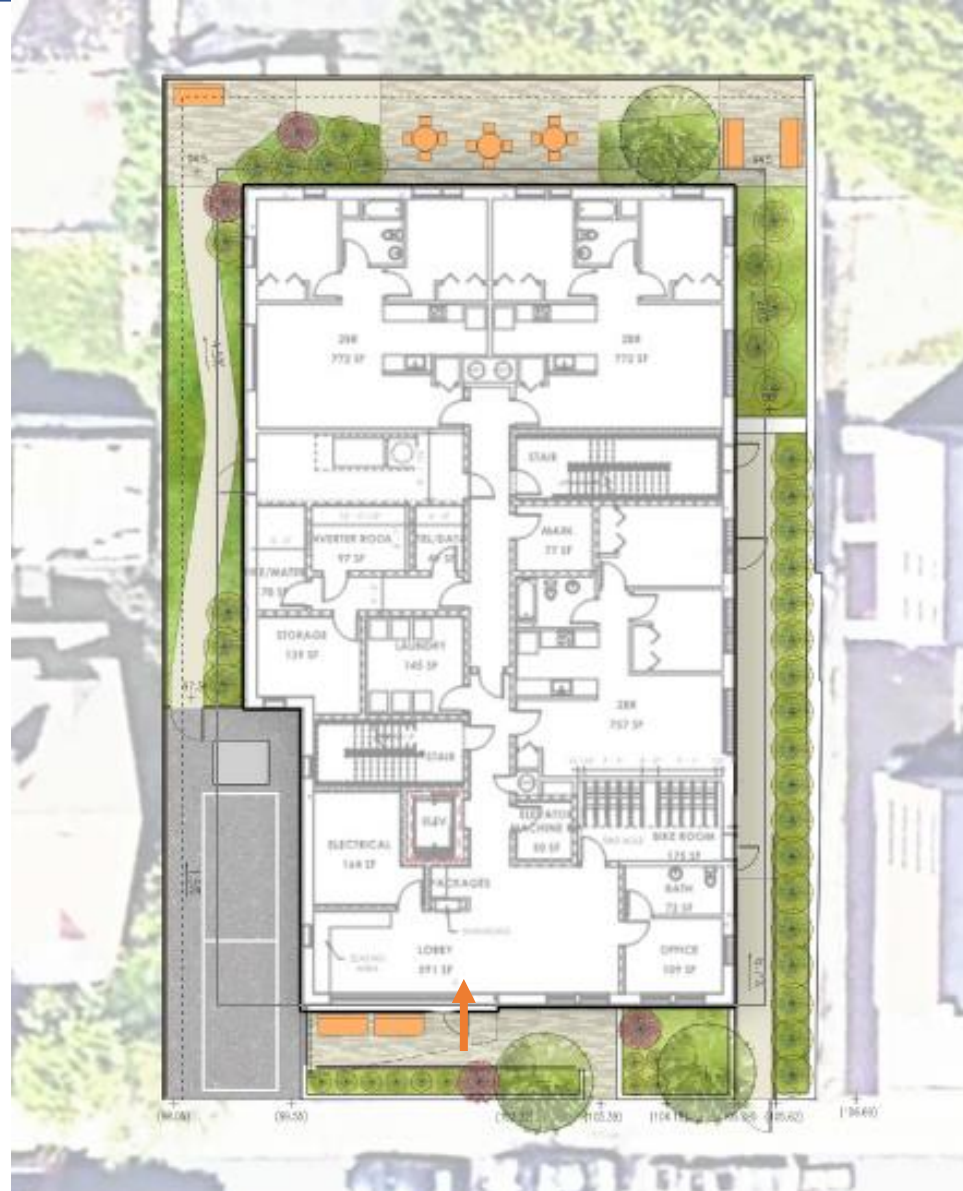

\*MOH = City of Boston – Mayor’s Office of Housing previously the Department of Neighborhood Development  
DHCD = Mass. Department of Housing and Community Development



# E+ Highland

## Project Details:

- 126 kW PV system (108% of energy use)
- EUI of -0.8
- 23 units – 1,2,3 bedrooms
- 5 stories – 30,200 sf + 6,800 sf parking
- 100% affordable (30 + 60% AMI)
- Art gallery/community room
- LIHTC credits/city/state funded
  
- Passive House Pre-Certification in-process
- ILFI\* Affordable Housing Pilot Program
- City of Boston E+ Green Building Program



\*ILFI = International Living Future Institute

# E+ Highland

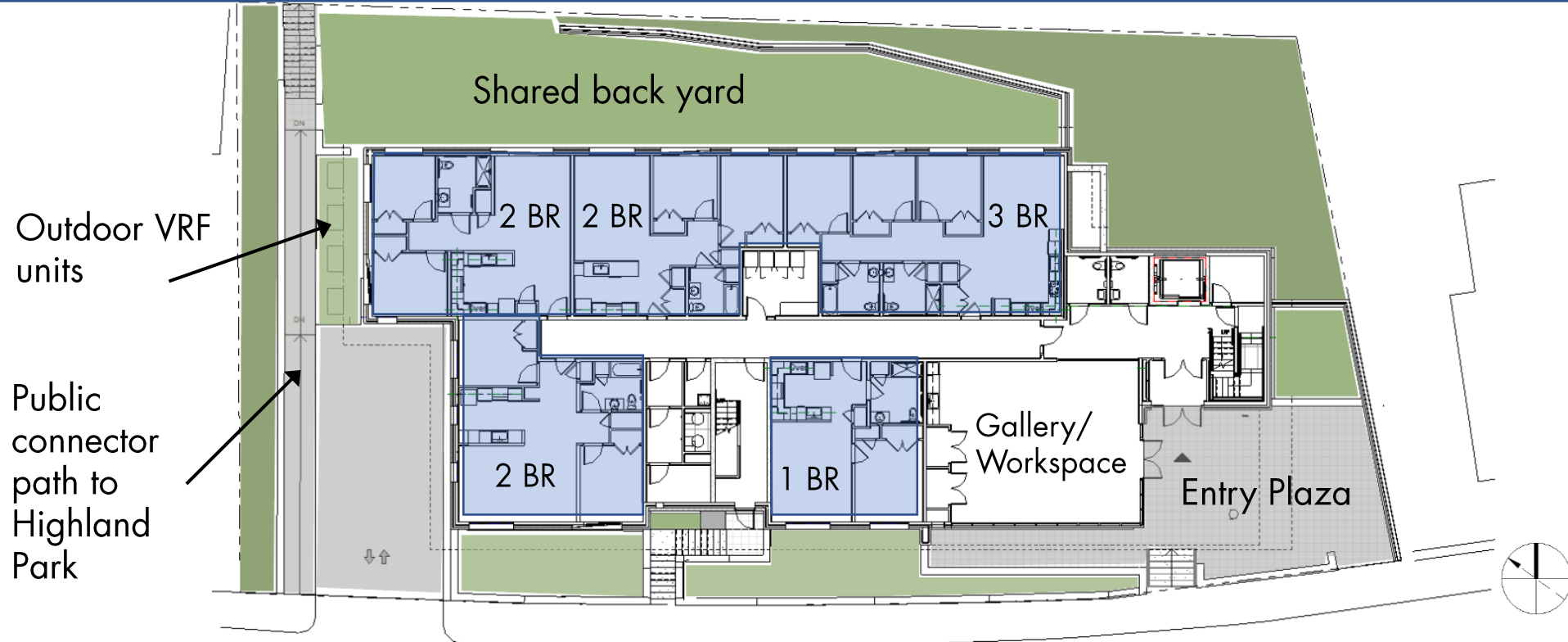

South West Elevation

# Changes in Policies And Guidelines – City of Boston



- **Carbon Neutral by 2050**
- **Mayor's office of Housing (MOH, formerly DND)**
  - Zero Emissions Building (ZEB) standards
  - All electric
  - CO2 target budget of 0.7-1.1 tons/person/year, or 1800kWh per person annually
  - Guidelines are based on Passive House Standards
- **Carbon Neutral Building Assessment**
  - All electric
- **Boston Climate Resiliency Checklist**
- **Article 37**
  - LEED certifiable
- **E+ Green Building Program (optional)**
  - Energy positive
  - All electric
- **No Parking Minimums on Affordable Housing projects**
  - Must have 60% affordable units





# Project Roadmap

## Project Development Team

"Rental"

"Condo"

**Central Systems**

**Dedicated Systems**

VRF/VRV HP's

"1 to 1" Systems

Larger Electrical  
Loads on "House"

Larger Electrical  
Loads on "Unit"

Meter

Meter

(Renewables more viable)

(Renewables less viable)

Larger Mech  
rooms **inside**

**building** required

More area for  
mech equip in

**units** required

### 1. Define Project Market Goals;

- Apartment Rental Units Vs. Home Ownership.
- Initial Market approach and timeframe will impact how the MEPFP Requirements

### 2. Determine basis of design for HVAC & Ventilation systems;

- Central vs. Dedicated ERV's
- Central vs. Dedicated DHW
- Central vs. Dedicated Heating/Cooling System

### 3. Define On-Site Renewable Energy & Utility Metering Req's;

- Central DHW Systems = Solar Thermal Potential
- Solar PV On Site = "Net-Metering" to Offset House Elec Loads

### 4. Integrate HVAC, DHW and Utility Systems Infrastructure within project Architecture;

- By determining Building facilities early in project, Owner, Designer and Engineering teams can reduce redesign and gain efficiency from project conception to completion

# Project Roadmap – Central Systems

- Larger Electrical loads on house panels = Larger elec. load to offset with PV array
- Central DHW systems allow the integration of sustainable features such as Solar Thermal DHW Production on site.
- As Central HVAC Systems will be powered from the House panels, the Owner will be responsible for larger portion of operating costs. Control systems allow Management teams to remotely control and monitor tenant energy consumption on site.
- Central systems will likely require additional common space/rooms depending on system selections. The location and size of supportive spaces for Electrical, HVAC, DHW equipment, as well as mechanical shafts and ceiling cavities will impact how systems are integrated within project.

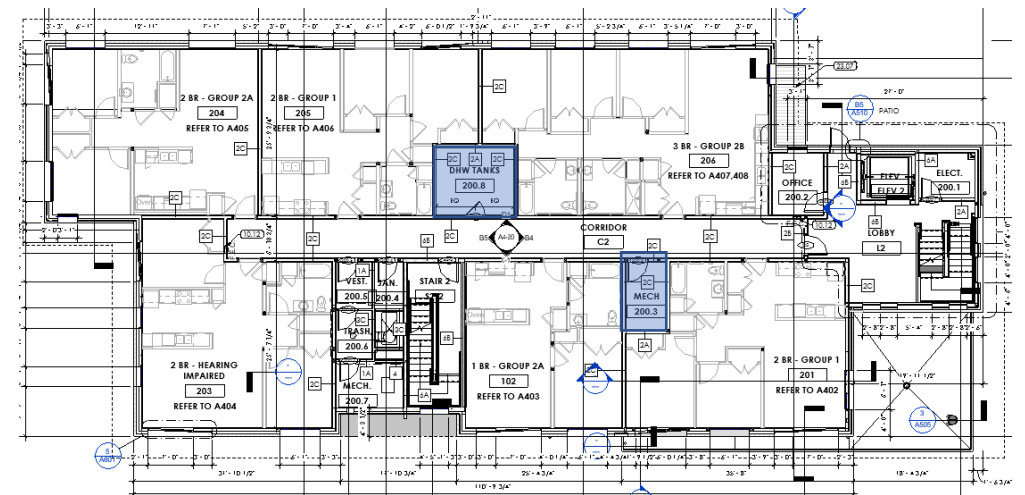
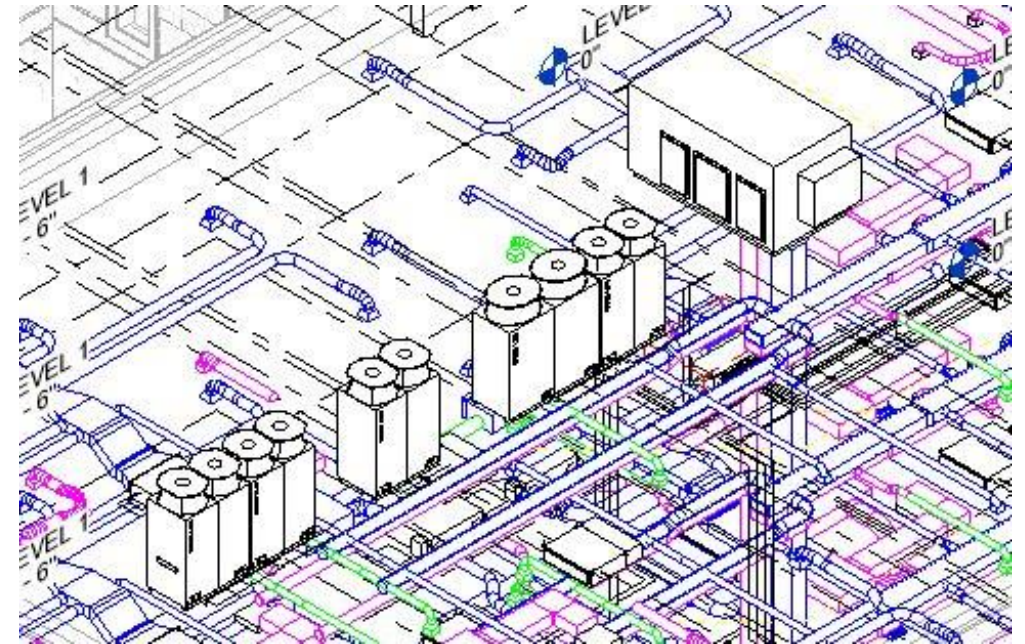

E+ Highland

# Project Roadmap – Dedicated Systems

- Smaller Electrical Loads on House = Owner is limited for larger Solar PV/Thermal system integration (Smaller “Common” or House Loads)
- With each Dwelling Unit having independent DHW & HVAC Systems, **more interior space within the Unit will be required** to support the MEPFP systems.
- Dwelling Unit MEP systems powered from the local Unit panels, which will result in **larger Unit electrical panels/space requirements**.
- Dedicated Heat Pump or Condenser Systems may **require more exterior space** for service/clearance compared to Central VRF/VRV equipment. Multiple systems may result in **more building penetrations** for dedicated refrigerant piping, control wiring and power wiring to serve each respective HP unit.

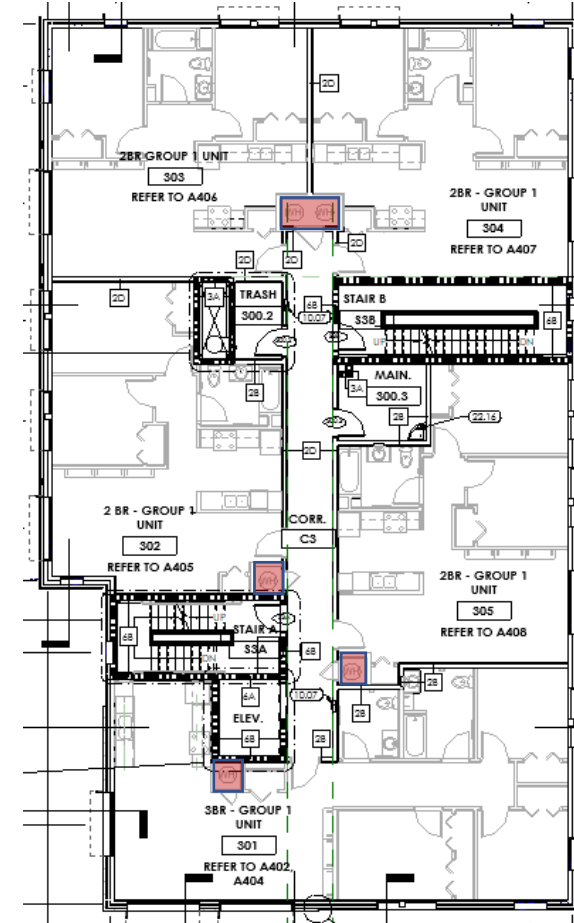

37 Wales



# Tools: Questionnaire & Working Sessions

## CLIENT RESPONSES

- Please use **Yellow Highlighter** text to indicate that the action item has been finalized/confirmed. This will represent a final determination/direction for us to incorporate within the project scope.
- Please use **RED** text to edit this word document with your responses regarding any additional clarification, question or comment you have for NSE.
- NSE will use **Green** text for responses for initial questions as well as any new items/questions proposed by your team.
- NSE will use **Green Highlighter** to represent critical path items, as well as to prompt further responses as we coordinate items.

Please add the date for each revision and start by indicating who responded or added a question.  
(eg: Studio G - Month/Day/Year)

Based on our conversations to date NSE has highlighted initial assumptions and determinations. Please review the highlighted items and comment/revise as required.

## General

1. Dwelling Units are to be Condos or **Rental**?
2. Is Energy Star certification a project requirement, **Yes/No**? **Certification will not be required but compliance with Energy Star is required.**
3. Will LEED certification be part of the project, **Yes/No**? **Certification will not be required but compliance with LEED Platinum is required.**
4. Is Passive House (PHIUS) a requirement for this project, **Yes/No**? **PHIUS+2018 requires Indoor AirPlus, DOE SER home.**
5. Is Net Zero a requirement for this project, **Yes/No**?
6. Is Power Positive a requirement for this project, **Yes/No**?
7. Will commissioning be used beyond the IECC 2018 & Pre-requisite LEED requirements, **Yes/No**?
8. Are there any accessible apartments, **Yes/No**? **A minimum of (1)3bed, (1)2bed, and (1)1bed will be accessible units.**
9. Is the intent that all apartments will be group-1 adaptable, **Yes/No**? **Apartments that are not in a Group 2 stack will be Group 1. That is 11 units which are all 2 bedroom units. 9 units will be sized to be adaptable Group 2 units.**

# Tools: Open Source Specs for High Performance Buildings

<https://linneansolutions.com/passive-house-specifications>

<https://kalinassociates.com/resource/phius-2022-education-session/>

014525-air tightness testing requirements-PHIUS 2021

018115-passive house requirements-PHIUS 2021

E+ HIGHLAND STREET 273 Highland Street, Roxbury, MA	Studio G Architects September 30, 2021
SECTION 018115 PASSIVE HOUSE REQUIREMENTS	
PART 1 - GENERAL	
1.1	GENERAL PROVISIONS
A.	Attention is directed to the CONTRACT AND GENERAL CONDITIONS and all Sections within DIVISION 01 - GENERAL REQUIREMENTS which are hereby made a part of this Section of the Specifications.
1.2	DESCRIPTION OF WORK
A.	Work Included: General requirements and procedures for compliance with Passive House Standards. Comply with the following: <ol style="list-style-type: none"><li>1. Passive House PHIUS+ 2018 certification or PHIUS+ Core certification.</li><li>2. International Living Future Institute (ILFI) Zero Energy certification.</li><li>3. US DOE Zero Energy Ready Homes (ZERH).</li><li>4. US EPA Energy Star Multifamily New Construction (MFNC) or New Homes v3.1.</li><li>5. US EPA Indoor airPLUS certifications</li><li>6. US EPA WaterSense Certified Homes and the Guide for Efficient Hot Water Delivery.</li><li>7. Massachusetts Stretch Energy Code.</li></ol>
B.	Related Work: The following items are not included in this Section and will be performed under the designated Sections: <ol style="list-style-type: none"><li>1. Section 011000 - GENERAL REQUIREMENTS for general submittal procedures, project meetings, and other requirements.</li><li>2. Section 014330 - MOCKUPS for exterior mockups related to passive house requirements.</li><li>3. Section 014525 - AIR TIGHTNESS TESTING REQUIREMENTS for other testing requirements.</li><li>4. Section 018110 - SUSTAINABLE DESIGN REQUIREMENTS for other sustainable design certification requirements.</li><li>5. Section 019100 - GENERAL COMMISSIONING REQUIREMENTS for other testing requirements.</li><li>6. Divisions 01 through 49 Sections for passive house requirements specific to the work of each of these Sections. Requirements may or may not include reference to passive house standards.</li></ol>
1.3	PERFORMANCE REQUIREMENTS
A.	Passive House Air Tightness: <ol style="list-style-type: none"><li>1. Individual Unit Air Tightness for Residential Units (Compartmentalization), Air Leakage: 0.30 CFM50 per sq. ft. of unit enclosure area, or less, demonstrated through blower door testing performed by the PHIUS+ Verifier.</li><li>2. Whole Building Air Tightness: Demonstrated through a blower door test performed by the PHIUS+ Verifier, at one of the following rates, or less:<ol style="list-style-type: none"><li>a. At 50 Pascals: 0.06 CFM50 per sq. ft. of building enclosure area,</li><li>b. At 75 Pascals: 0.08 CFM75 per sq.ft of building enclosure area.</li></ol></li></ol>
PASSIVE HOUSE REQUIREMENTS 018115 - 1	

# Tools: Airtable + Trello

## Research / Presenting / Project Management

- Sorting data
- Organizing products
- Tracking energy use

## Airtable

The screenshot shows an Airtable database with a grid view of appliance data. The table is organized into sections by appliance type: Dishwasher and Washing Machine. Each row contains detailed specifications, energy consumption metrics, and links to product pages.

APPLIANCE TYPE	Manufacturer & Model	Appliance Type	Status	A Sayo...	Ene...	Wat...	Co...	INFO	Link	Comments
Dishwasher (From Energy Star)	Summit - DW2435SSADA	Dishwasher (From Energy Star)	BEST	260 kwh/year	234 kWh/yr	2.66 gal/cycle		\$819.00	Dimensions Height: 32.0" Width: 23.5" Depth: 22.38"	ADA compliant
Washing Machine	Speed Queen - COMMERCIAL COIN BOX SFNNCASP116TW01 (PUMP) SFNNCASG116TW01 (GRAVITY) CARD SFNNYASP116TW01 (PUMP)...	Washing Machine	BEST	116 KWH/year, MEF 2.38	44 kWh/yr	MEF: 2.2 IWF: 4.0 13.68 gal/cycle	WHITE	\$2,952.00	Width: 26 7/8" Depth: 27 3/4" Height: 40 7/16"	27 Inch Commercial Capacity, 1200 RPlv Drop Installation, E Compliant
Washing Machine (From Energy)	LG - GCWL1069*** COMMERCIAL NON-HEATER FRONT LOAD WASHER	Washing Machine (From Energy Star)	BEST	116 KWH/year, MEF 2.38	100 kWh/yr kW/cycle: 0.076	MEF: 2.4 IWF: 4.0 Consumption: 13.8 gal	STAINLESS STEEL	\$	GIANT Washer (WHXD) 29.5 x 41.9 x 31.4	3.7 cu.ft Standard Coin devices must Inverter Direct Drive Multi Heat Treatme Premium Powder C Atomizing & Twin

## Trello

The screenshot shows a Trello board with several cards organized into columns. The cards contain various types of content, including text notes, images, and tables.

- Research**: Contains text about Carbon Cure and window research questions, along with a lighting toolkit image.
- LEED guidelines**: Contains text about LEED water requirements and a table with columns for 'Good', 'Better', and 'Best'.
- ILFI CORE Requirements**: Contains registration information and a CORE standard image.
- PHIUS tasks**: Contains text about updating the energy model and a table of PHIUS inputs.
- Numbers to Remember**: Contains text about duct insulation recommendations and a table of numbers.



# Tools: THERM



## Envelope Detail Improvements - Revised Detail at 50.4°F

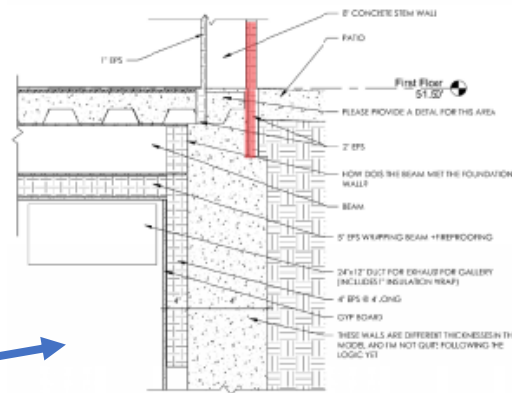

Original Detail - 2" EPS along exterior face

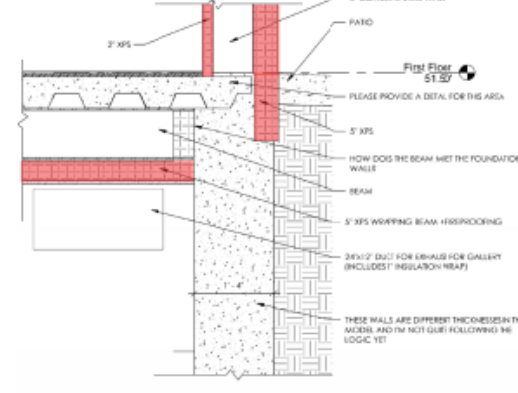

Modified Detail - 5" XPS along exterior face  
 - 2" XPS along interior face  
 - 5" XPS along underside of concrete slab  
 - XPS along steel I beam connector plate

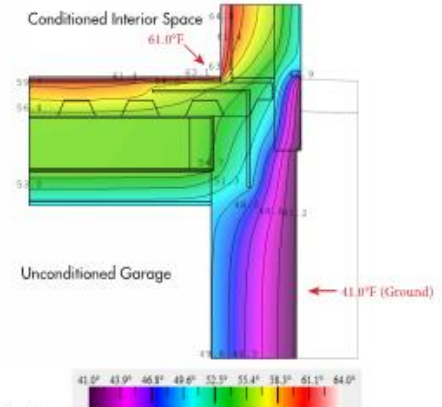

Modified Detail at 50.4°F

Best  
 Psi value :  
 0.055  
 BTU/hr.ft.F

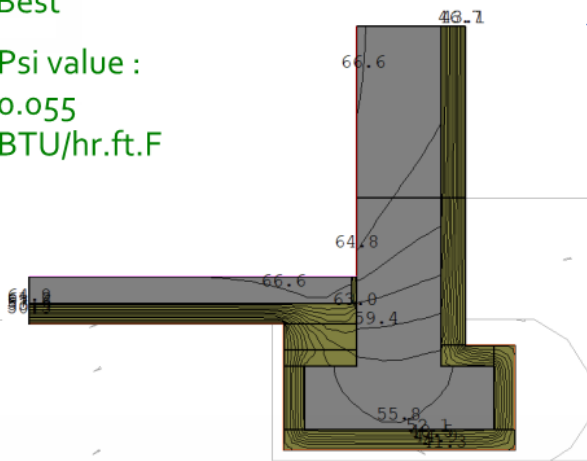

Psi value :  
 0.302  
 BTU/hr.ft.F

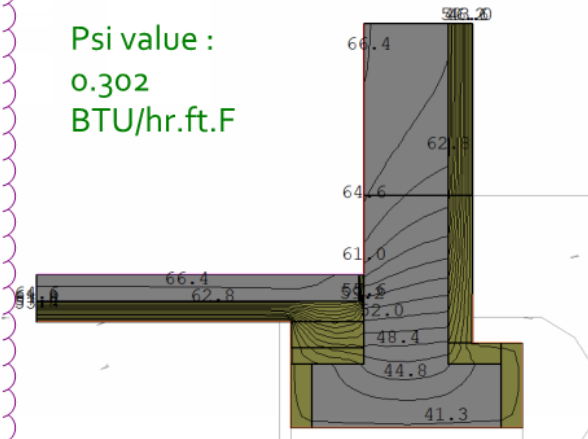

Choose details that address air sealing, continuous insulation and potential moisture challenges

# Tools: WUFI Passive

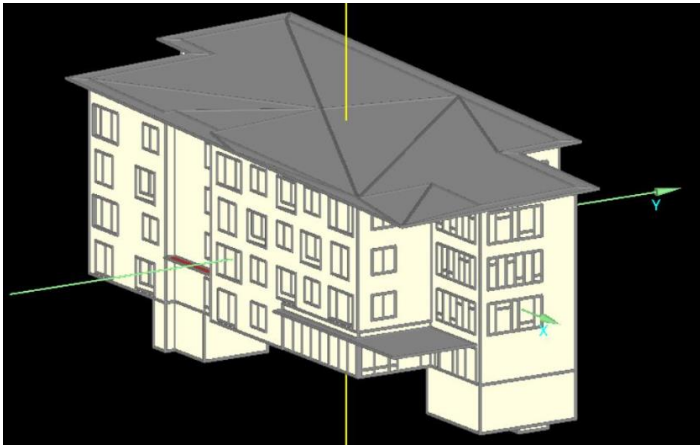









WUFI Tracks overall energy use as well as:

- All the energy use of fans and motors
- Elevator energy use
- Internal Heat Gains and Heat Loss through pipes, etc

WUFI – more frequent modeling is better, changes add up + informs systems decisions:

- Reduce window area = improvement
- 37 Wales – dialed in shading devices – for cooling loads and buildability sweet spot

## Building Envelope Metrics

	IECC 2018	DND	Proposed	Notes:
 pEUI (Source)	No Requirement	No Requirement	<b>0</b>	PHIUS requires min. 3,840 kwh/person
 pEUI (Site)	No Requirement	No Requirement	<b>Net Positive</b>	
 Walls	R value: 13+3.8 ci	R value: 36	<b>R value: 36</b>	based on WUFI Passive energy model per PHIUS+2018 protocol
 Roof	R value: 30 ci	R value: 60	<b>R value: 60</b>	
 Slab/Floor	R value: 10	R value: 21	<b>R value: 20</b>	based on WUFI Passive energy model per PHIUS+2018 protocol
 Windows	U value: 0.38 fixed 0.45 operable	U value: 0.18-0.22	<b>U value: 0.15</b>	based on WUFI Passive energy model per PHIUS+2018 protocol
 Airtightness	0.24 CFM/ft2 @ 75 Pa optional	0.06 CFM/ft2 @ 50Pa	<b>0.06 CFM/ft2 @ 50Pa</b>	PHIUS+2018 protocol
 Thermal Bridge	No Requirement	No Requirement	<b>Thermal Bridge Free</b>	

Note: ci = continuous insulation, WWR = Window-to-wall Ratio

# Tools: WUFI Passive

Key areas to save energy:

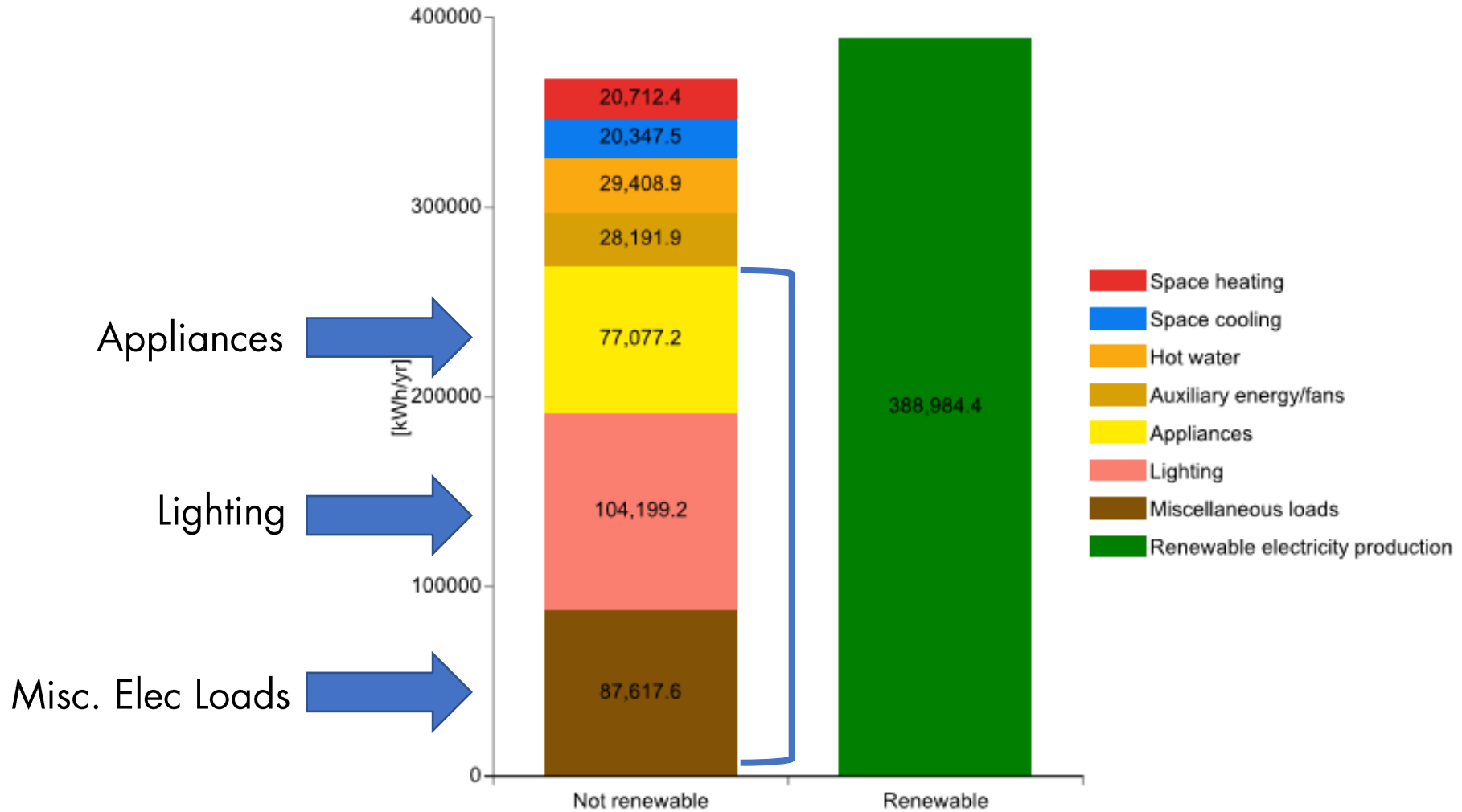
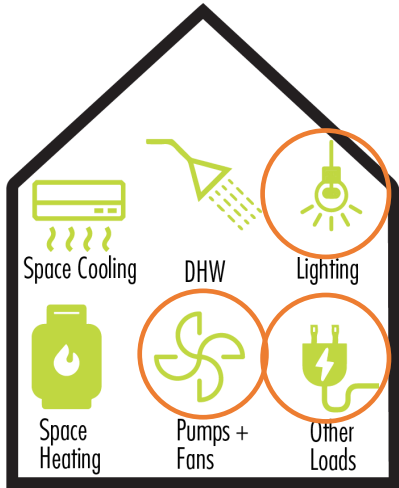

E+ Highland WUFI Energy Analysis



# Designing for Passive House: Integrated Strategies

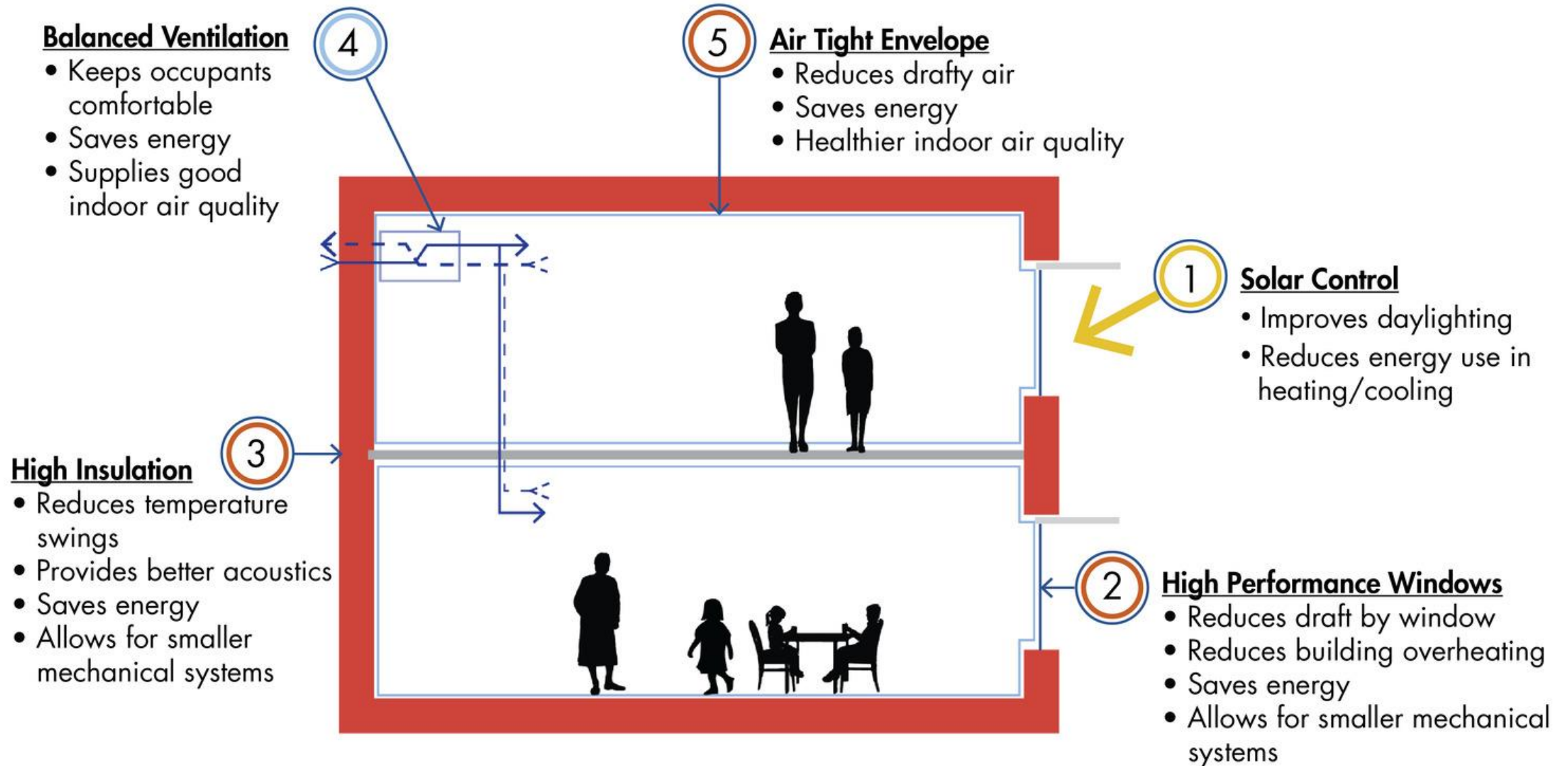

# Designing for Passive House: Wall Sections

## 37 Wales

- Roof = R60
- Walls = R37
- Slab = R20
- Windows =  $U_w=0.17$

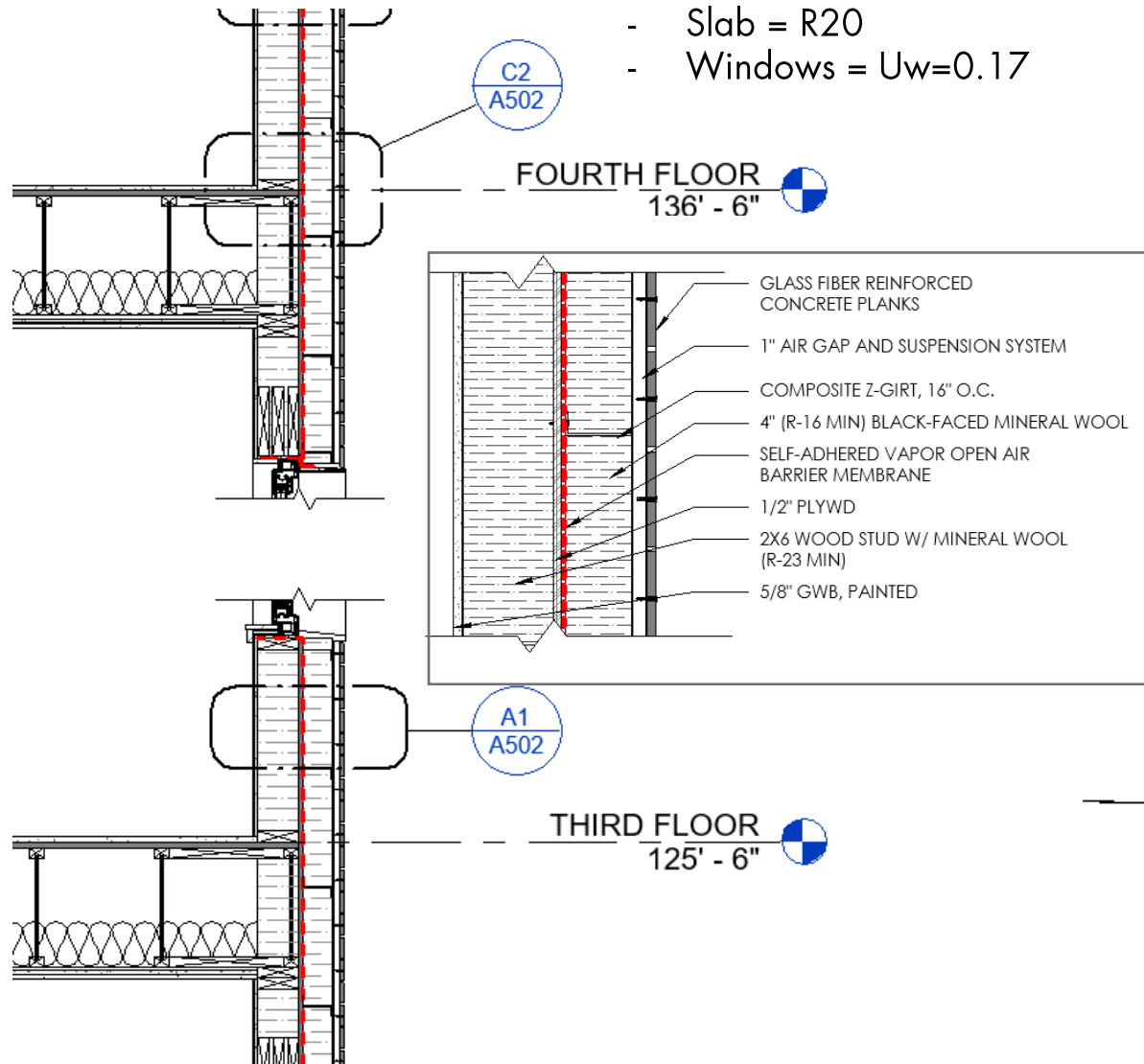

## E+ Highland

- Roof = R60
- Walls = R37
- Slab = R20
- Windows =  $U_w=0.14-0.15$

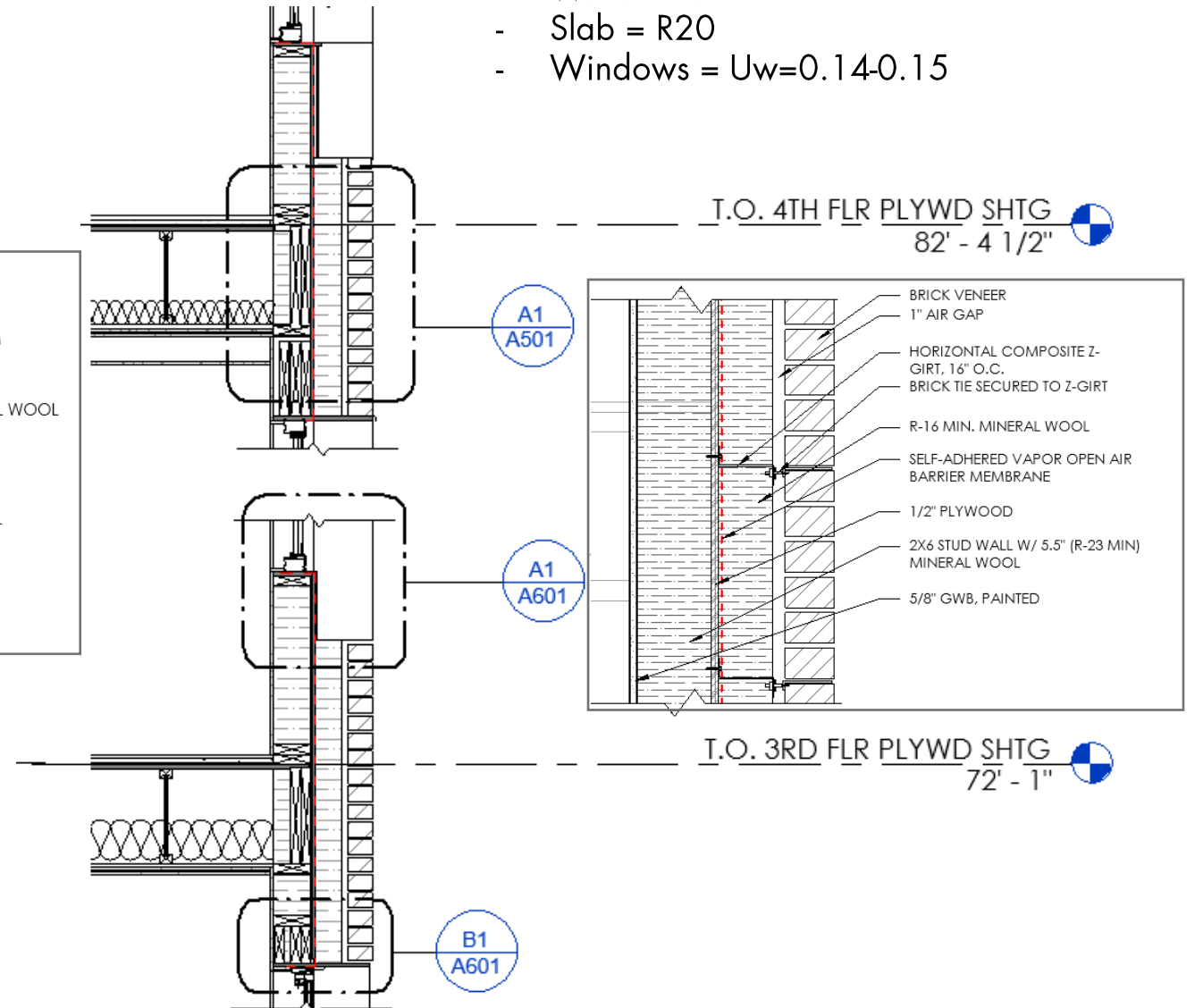

# Strategies: Domestic Hot Water

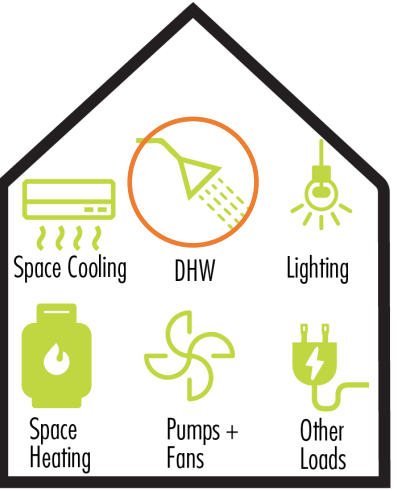

- Pipe Length matters
- Equipment location matters

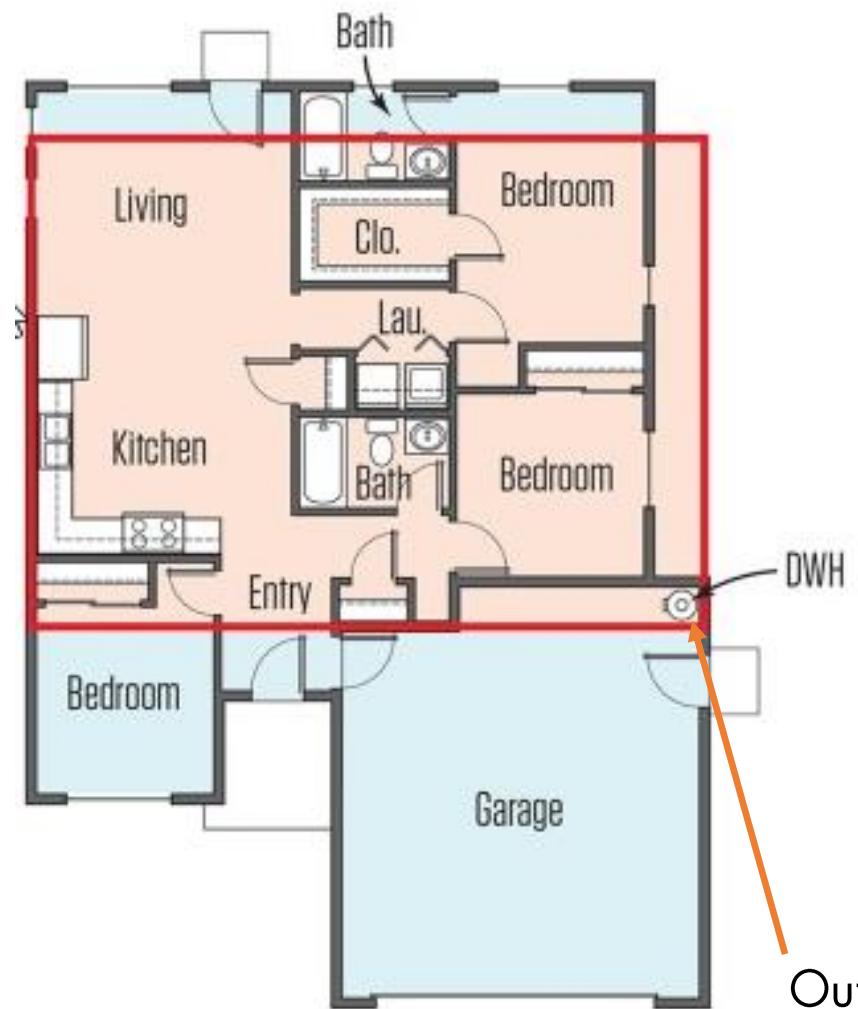

Outside the envelope, longer pipe lengths

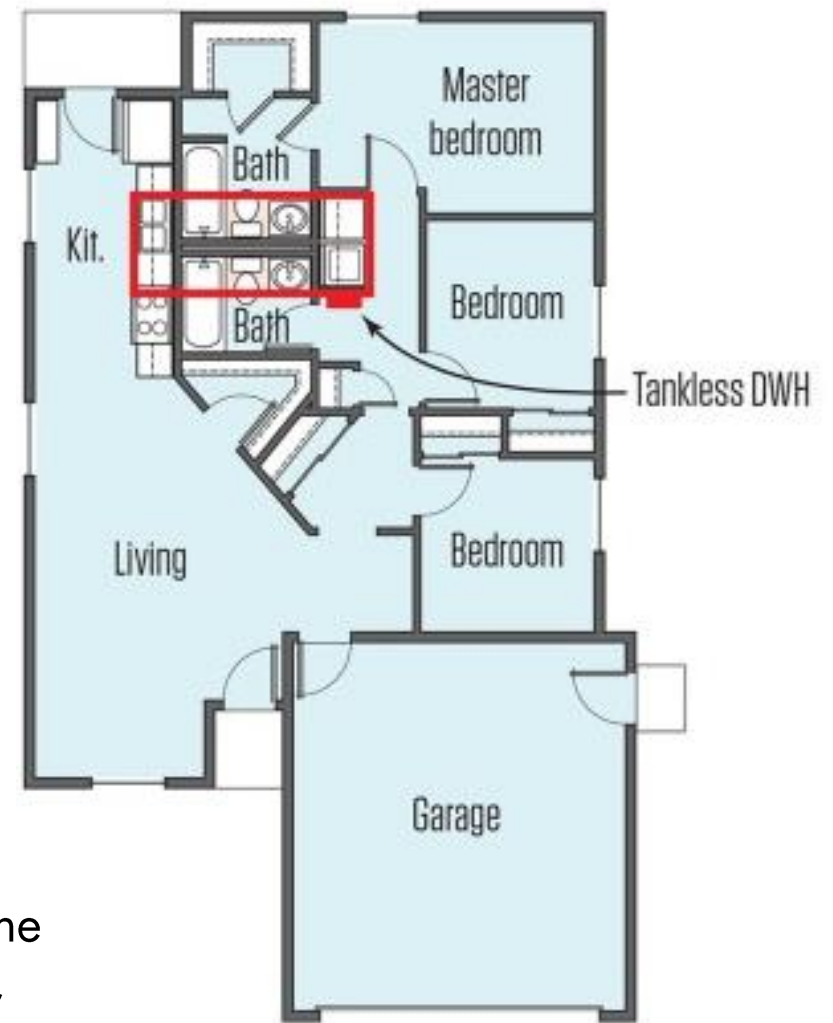



# Strategies: DHW – Centralized vs Individual

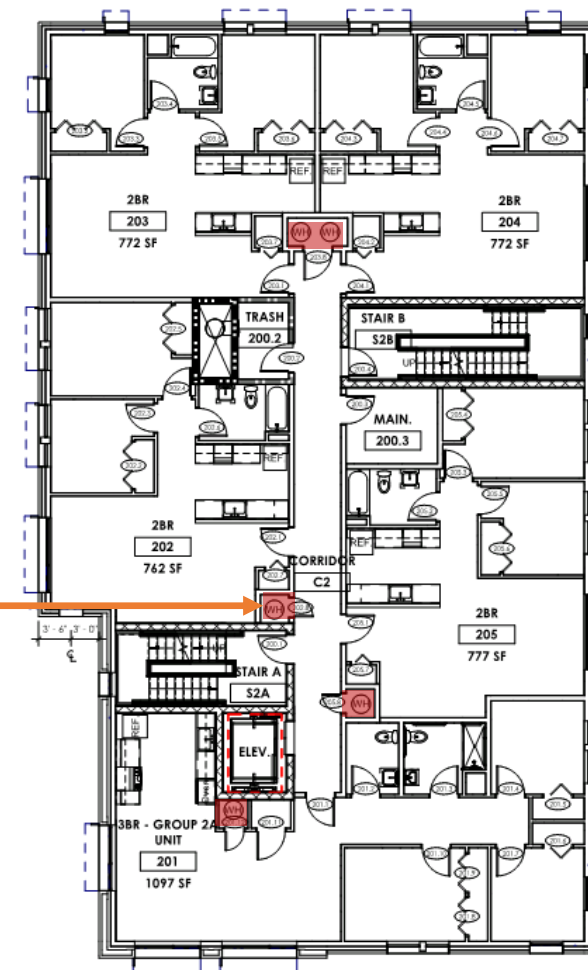
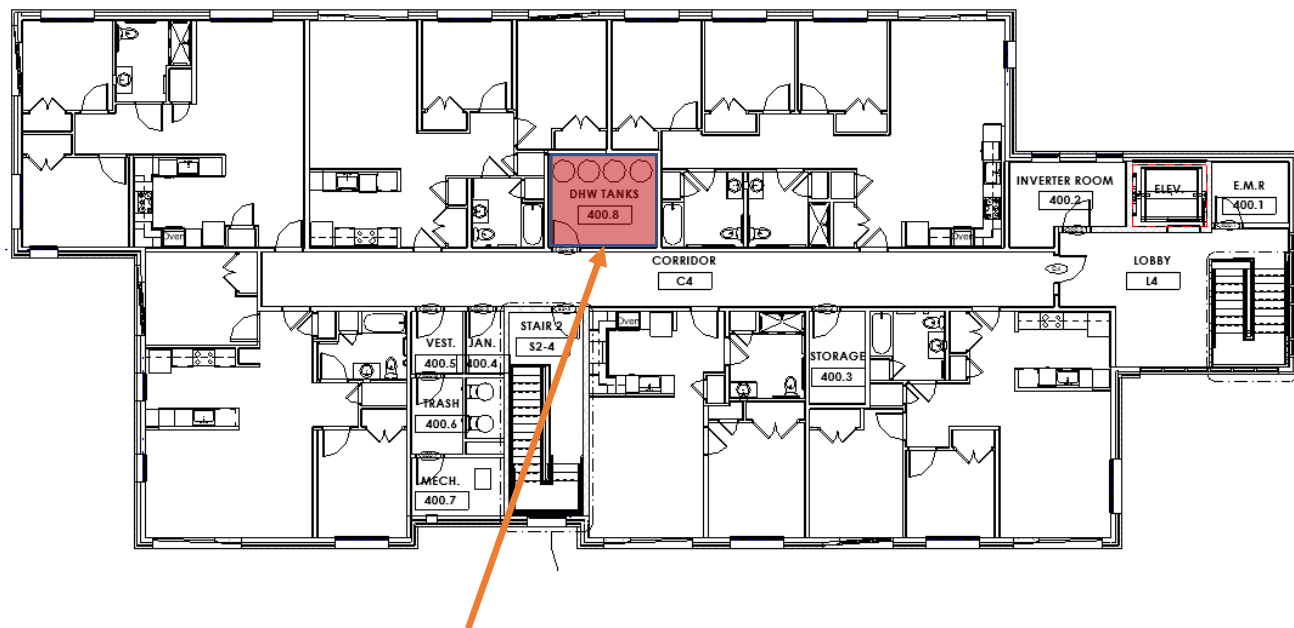
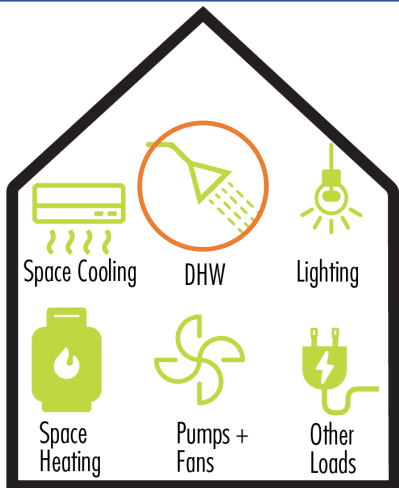

- Floor space matters
- Heat loss matters
- Efficient stacks matter

## E+ Centralized system:

- Watersense calculation and heat loss from central system was smaller than individual tank system.
- The floor plan had space for the centralized system
- Plumbing design has efficient risers with recirc. pumps + located in center of the building

## 37 Wales Decisions:

- No space for the centralized system due to tight lot and need for minimum unit count.

# Strategies: Reduce plug, elevator, appliance & lighting loads

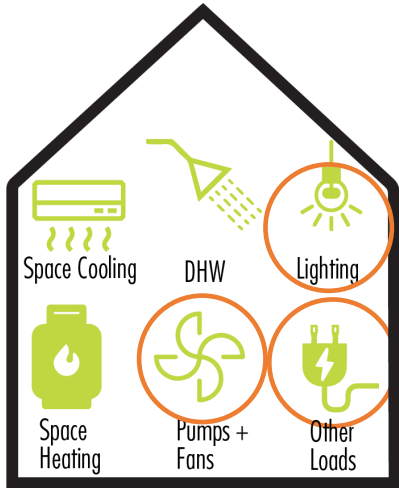

- Ask for elevator energy specs
- Research each appliance energy use – Energy Star database
- Research fan energy use

Estimated Energy Cost Per Year: \$217.50	
<b>Power</b>	
Starting Current:	34 amps
Nominal Current:	26 amps
Drive Output:	8.6 KW
Nominal Energy Demand Per Year:	1504.15 KWh/y
<b>Performance</b>	
Floor-to-Floor Time Based on Average:	14.10 s
Door Open Time (75% open):	2.2 s
Door Close Time:	4.1 s
Horizontal Vibration (max):	<15 mg
Vertical Vibration (max):	<25 mg
Airborne Sound - Inside Elevator Moving:	53 dB (A)
Airborne Sound - Hallway Elevator Moving:	53 dB (A)
Maximum Number of Trips Per Hour:	180

[Print](#)

Schindler Elevator Calculation



- Why no rating for Commercial dryers?

60 watt Incandescent	14 watt CFL	12 watt LED
Yearly Operating Cost - \$12.92	Yearly Operating Cost - \$3.01	Yearly Operating Cost - \$2.58
Energy Usage - 60w	Energy Usage - 14w	Energy Usage - 12w
Brightness(Lumens) - 800	Brightness(Lumens) - 800	Brightness(Lumens) - 800
Bulb Lifetime- 750 Hours	Bulb Lifetime - 10,000 Hours	Bulb Lifetime- 50,000 Hours+
	\$58 Lifetime Savings over an incandescent with the same brightness	\$200 Lifetime Savings over an incandescent with the same brightness

4everled

- Watts/sf matters
- Choose efficient fixtures and layouts
- Use Occupancy Sensors in common spaces
- Balance between daylighting and fixture efficiency

# Strategies: Heating/Cooling/Ventilation

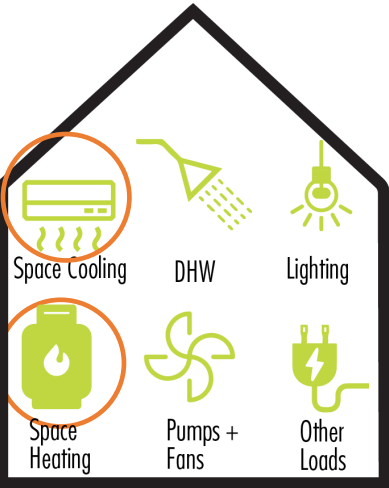

## E+ vertical units + floor unit

- Vertical units = fan coil – ducted
- Floor unit = smaller, intake and outtake on the same unit – not ducted
- Soffits to accommodate units in ceilings
- ERV at floor for units and in ceiling for common areas

## 37 Wales

- Horizontal ceiling units save floor space
- More building penetrations from each unit

Vertical units take up floor space, but better when ceiling heights are limited



E+ Highland

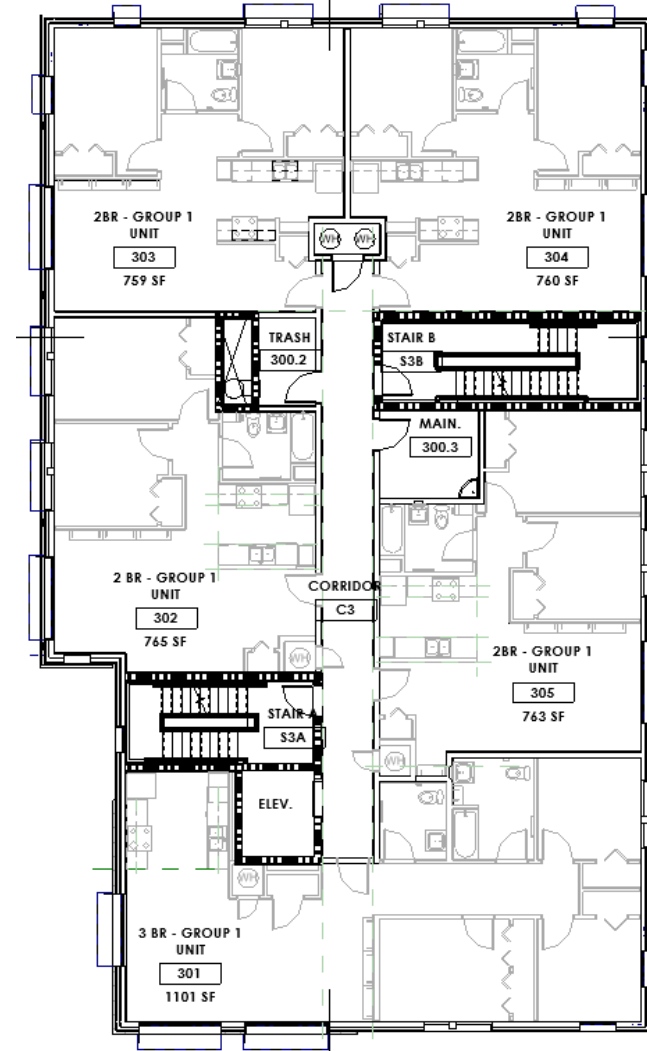

37 Wales



# Systems: Two Project Approaches



## E+ Highland – 23 units

- Central air source heat pump systems (space heating / cooling)
- Central ERV systems per floor to serve dwelling units
- Central air source heat pump water heater plant (domestic hot water production)
- Vertical ducted fan coil units serving dwelling units
- 10'-0" fl to fl height



## 37 Wales – 20 units

- Central air source heat pump systems (space heating / cooling)
- Individual ERV systems per dwelling unit
- Individual air source heat pump water heaters per unit (domestic hot water production)
- Horizontal ducted fan coil units serving dwelling units
- 11'-0" fl to fl height

# E+ & 37 Wales: HVAC Basis of Design

## Air Source Heat Pump (ASHP) – VRF / VRV Space Heating & Cooling

### System Overview:

- Exterior Air Source Heat Pump (HP's) Systems serve interior Fan Coil Units (FCU's) via refrigerant piping (RL&RS).
- HP system provides simultaneous heating and cooling via branch-box valve controller.
- Terminal fan coil units can operate in either heating or cooling to satisfy local thermostat set point.
- 100% electrically operated system providing superior system efficiencies and allowing reduction in emissions compared to fossil fuel technologies.
- R-410a refrigerant based technology



EXTERIOR HEAT PUMP

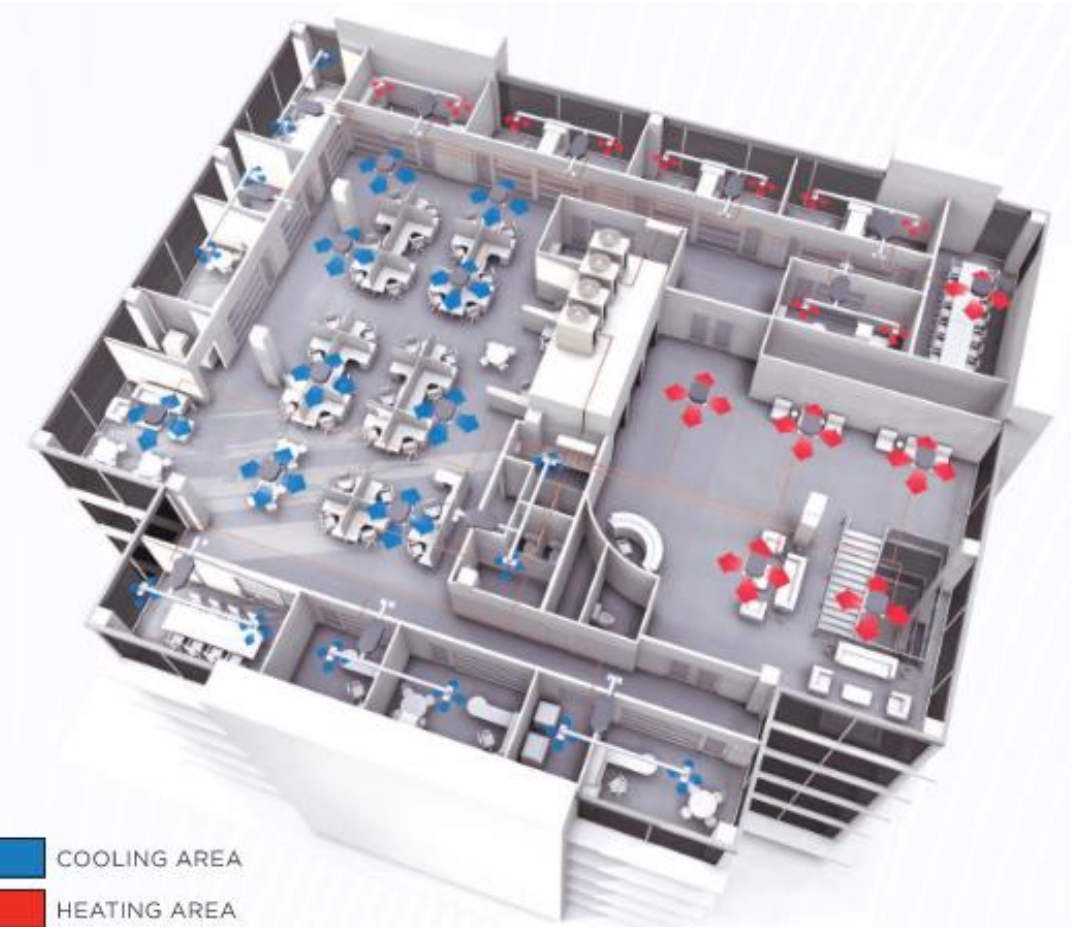

# E+ Highland: HVAC Basis of Design

## Air Source Heat Pump (ASHP) - space heating & cooling

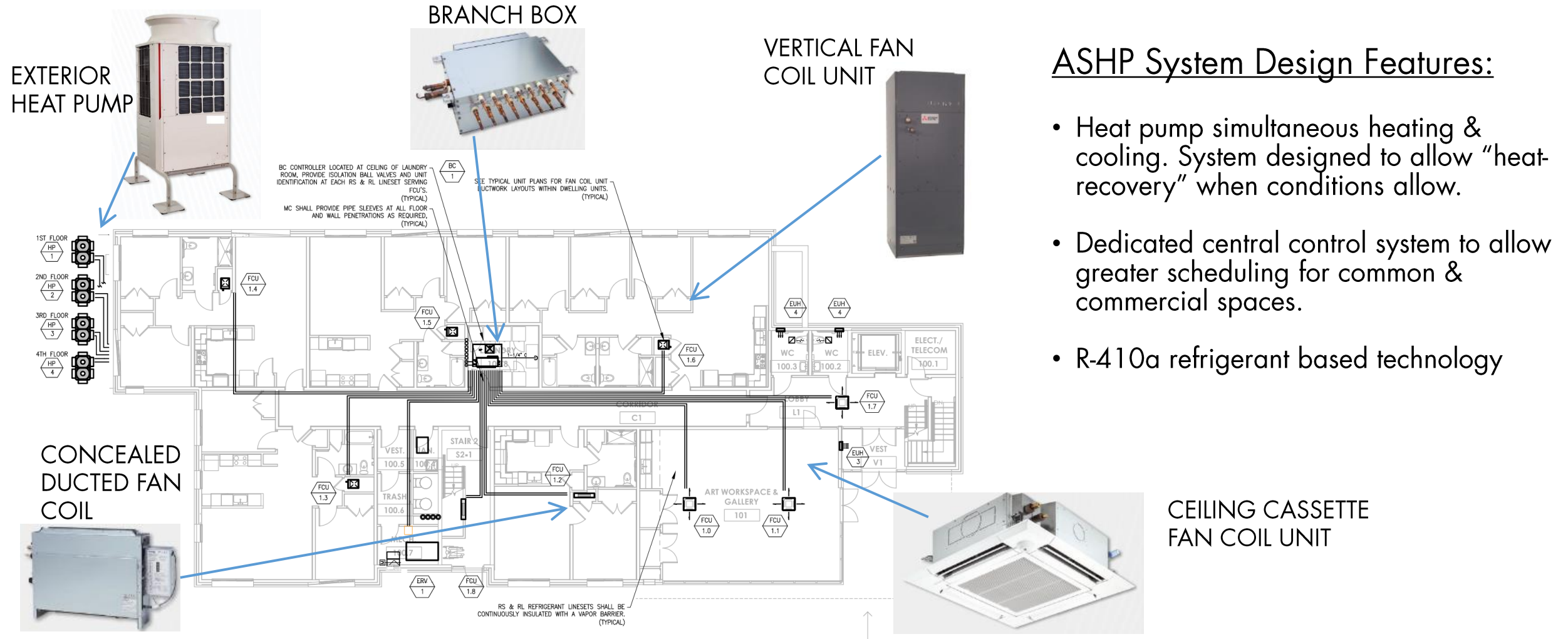



# E+ Highland: HVAC Basis of Design

## Air Source Heat Pump System Overview:

- Exterior Mounted **Air Source Heat Pump (HP)** System
- Indoor **Branch Box Controller (BC)** to allow Simultaneous Heating and Cooling System Operation.
- Indoor **Terminal Fan Coil Unit (FCU)** to provide space heat and cooling.

Indoor Units:	11 / 1 to 48	
Capacity:	199 / 96 to 288 (103.6%)	
* Connectable capacity is not actual capacity.		
Total Pipe Length:	956.7 / 2267.7	feet
Furthest Actual:	230.0 / 541.0	feet
Furthest Equiv.:	256.2 / 623.0	feet
Furthest IU from BC Actual:	120.0 / 188.9	feet
Furthest IU from BC Equiv.:	129.8 / 188.9	feet
Furthest IU from BC Thru Sub BC Actual:	0.0 / 0.0	feet
Furthest IU from BC Thru Sub BC Equiv.:	0.0 / 0.0	feet

### Correction Factors

Outdoor Unit Capacity:	1.01	1.00
Temperature:	1.03	1.03
Piping Length:	0.88	0.95
Defrosting:	-	0.95
User Derate:	1.00	1.00
<b>Total Derate:</b>	<b>0.92</b>	<b>0.93</b>
Additional Refrigerant:	61.5	lb
<b>Total Refrigerant Amount:</b>	<b>113.6</b>	<b>lb</b>

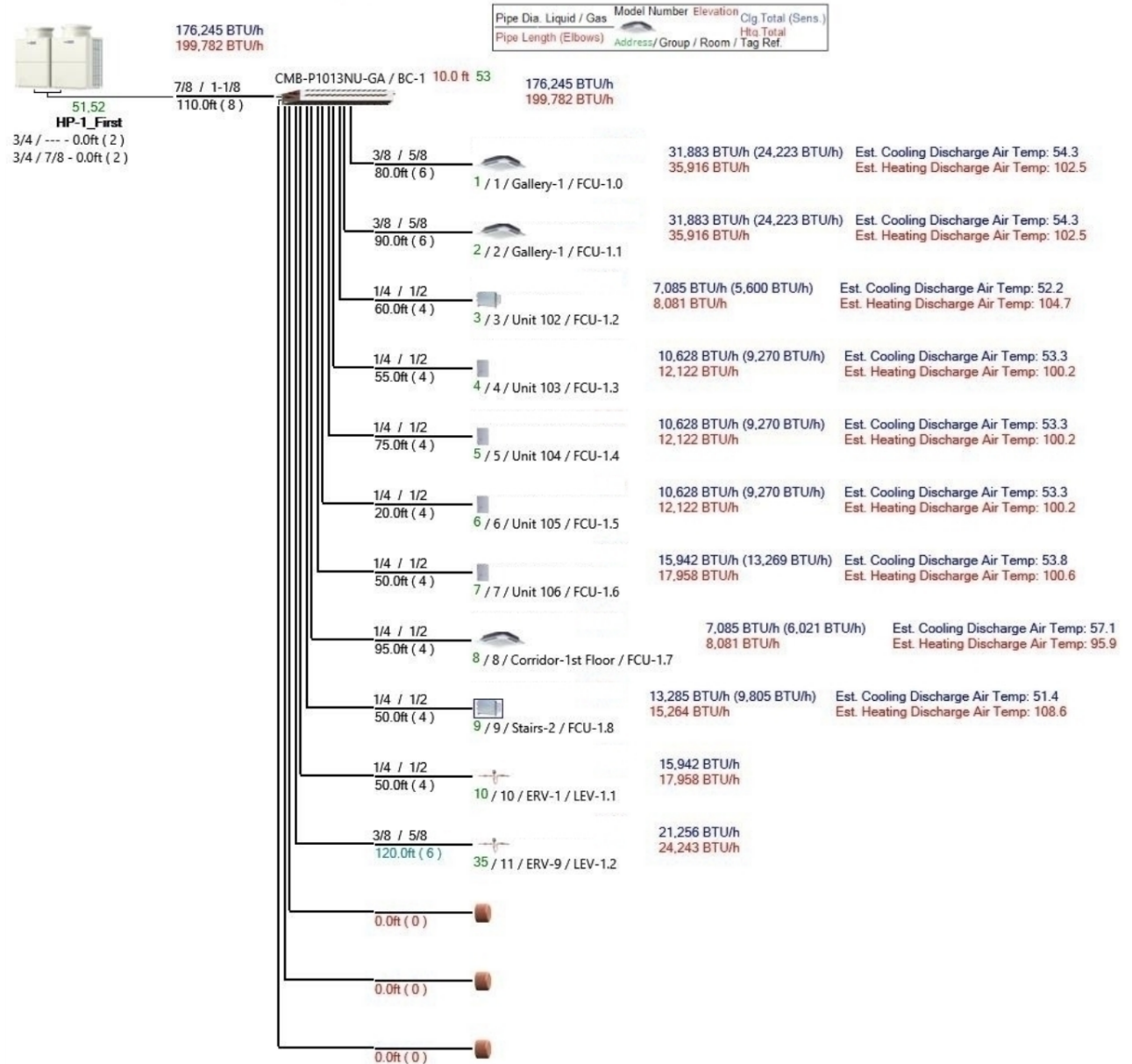

# E+ Highland: HVAC Basis of Design

## Air Source Heat Pump (ASHP) - space heating & cooling

### Dwelling Unit Heating & Cooling:

- Vertical ducted fan coil unit (FCU) to be located within dedicated closet
- System operates to satisfy local thermostat set point
- ECM variable speed blower motor

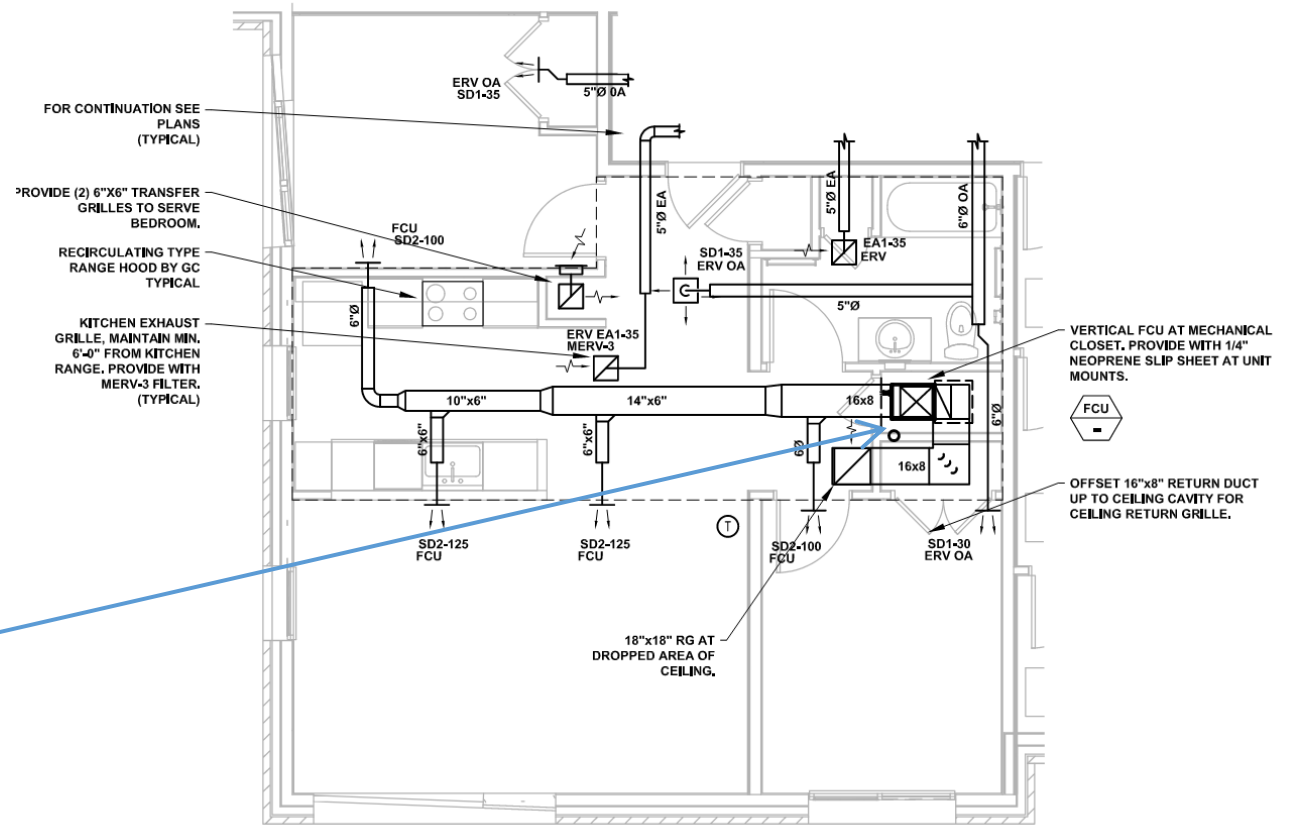
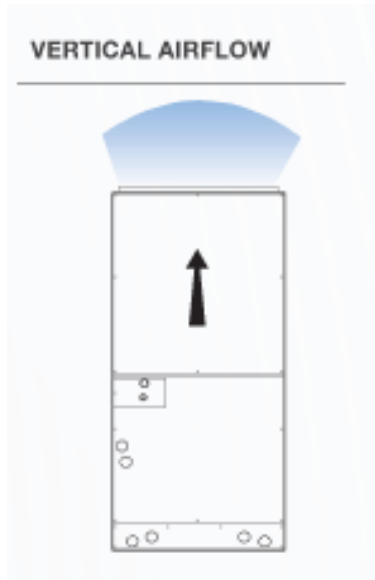

2 TYPICAL 2 BR UNIT MECHANICAL PLAN  
M301 SCALE: 1/4" = 1'-0"

# 37 Wales: HVAC Basis of Design

## Air Source Heat Pump (ASHP) - space heating & cooling

### Dwelling Unit Heating & Cooling:

- Horizontal ducted fan coil unit (FCU) to be located within dedicated closet.
- System operates to satisfy local thermostat set point.
- ECM variable speed blower motor

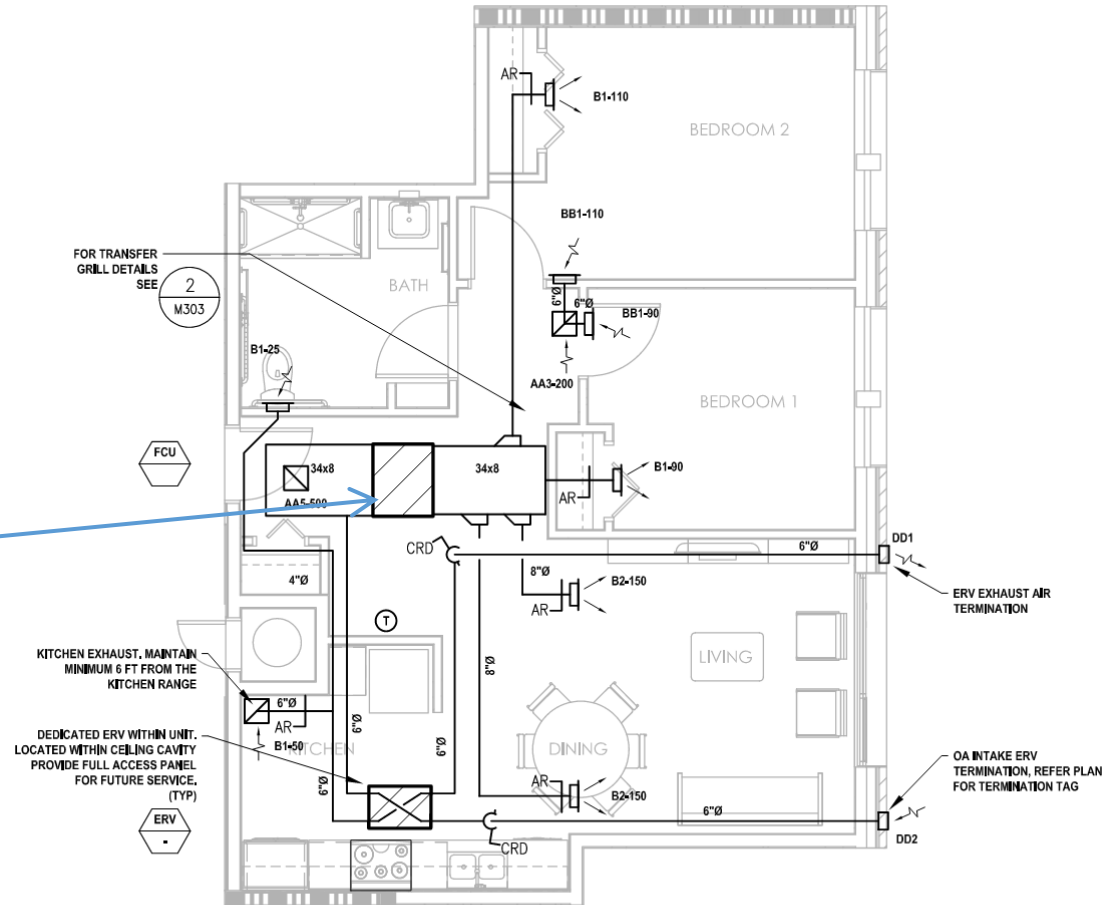
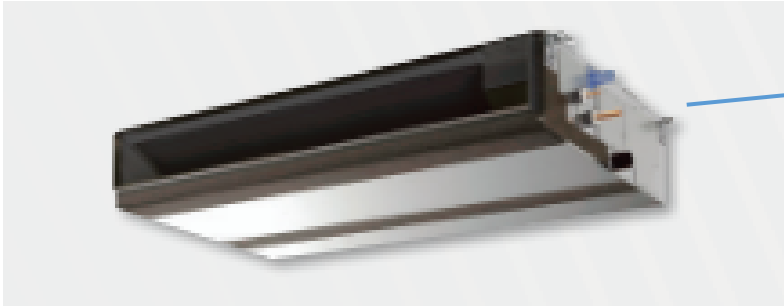



# PHIUS: Ventilation

## PHIUS "Whole-Building" Ventilation Diagram

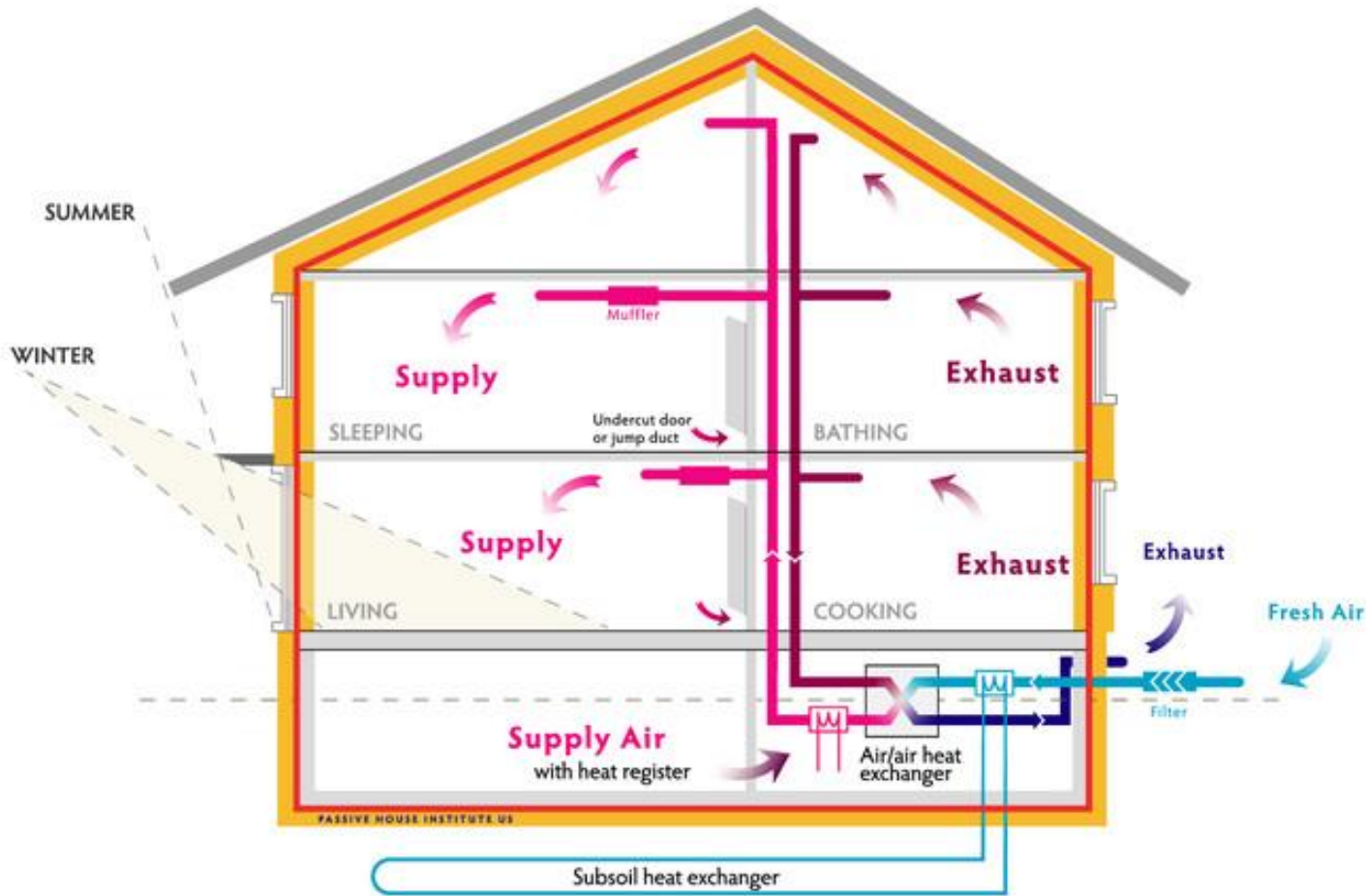

### System design features:

- High efficiency passive house certified ERV system with 85%+ system efficiency.
- Central ERV serving dwelling units per floor. ERV to provide continuous ventilation each dwelling unit space.
- Gallery space provided with dedicated ERV system for unocc/occ scheduling as well as demand ventilation control via local co2 space sensors.
- Corridor & common areas provided with dedicated ERV systems per floor.

# E+ Highland: HVAC Basis of Design

## Central Energy Recovery Ventilator (ERV) – space ventilation system

### System design features:

- High efficiency Passive House certified ERV system with 85%+ system efficiency.
- Central ERV serving dwelling units per floor. ERV to provide continuous ventilation for each dwelling unit space.
- Gallery space provided with a dedicated ERV system for unocc/occ scheduling as well as demand ventilation control via local CO2 space sensors.
- Corridor & common areas provided with dedicated ERV systems per floor.

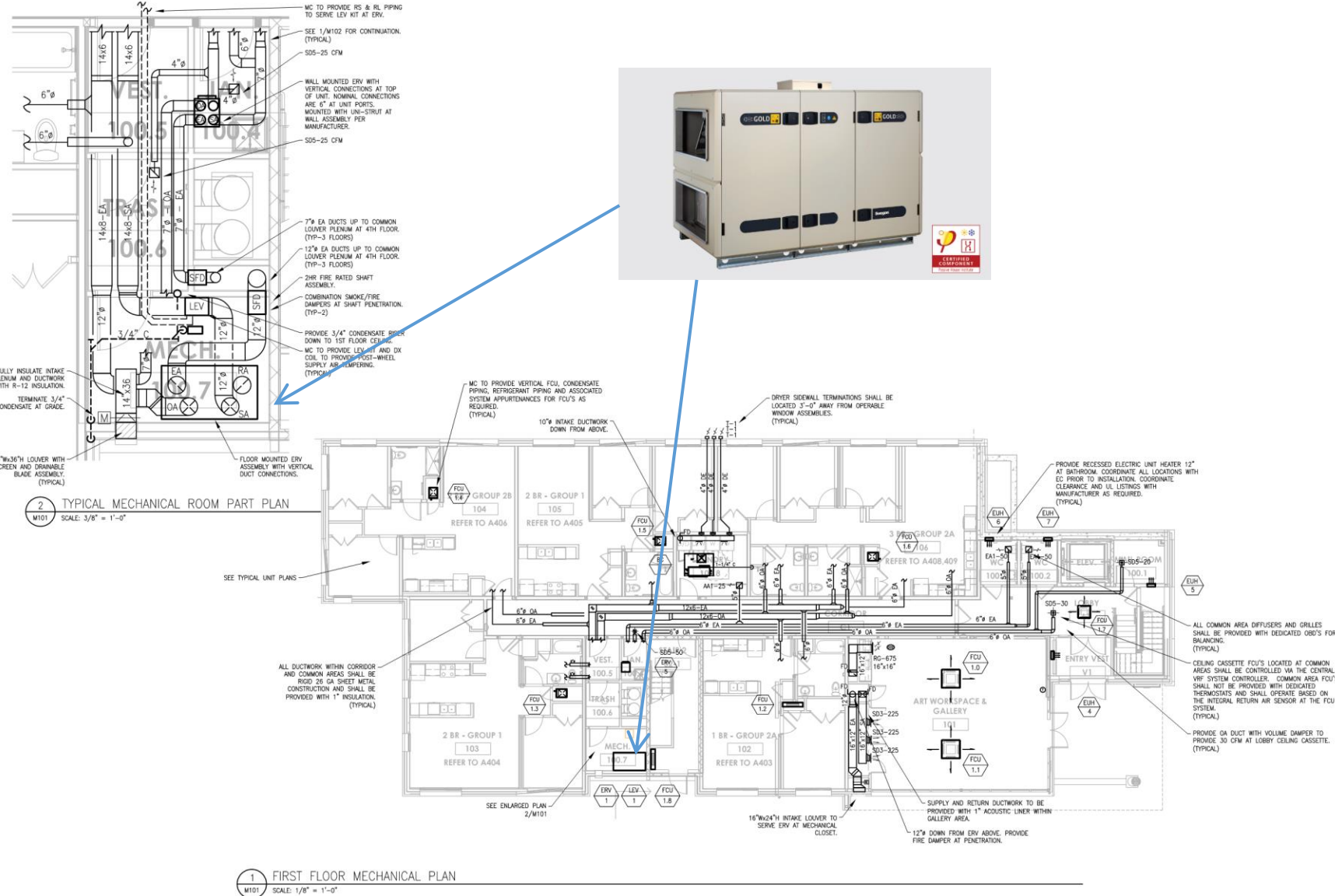

# 37 Wales: HVAC Basis of Design

## Individual Energy Recovery Ventilator (ERV) – DU ventilation system

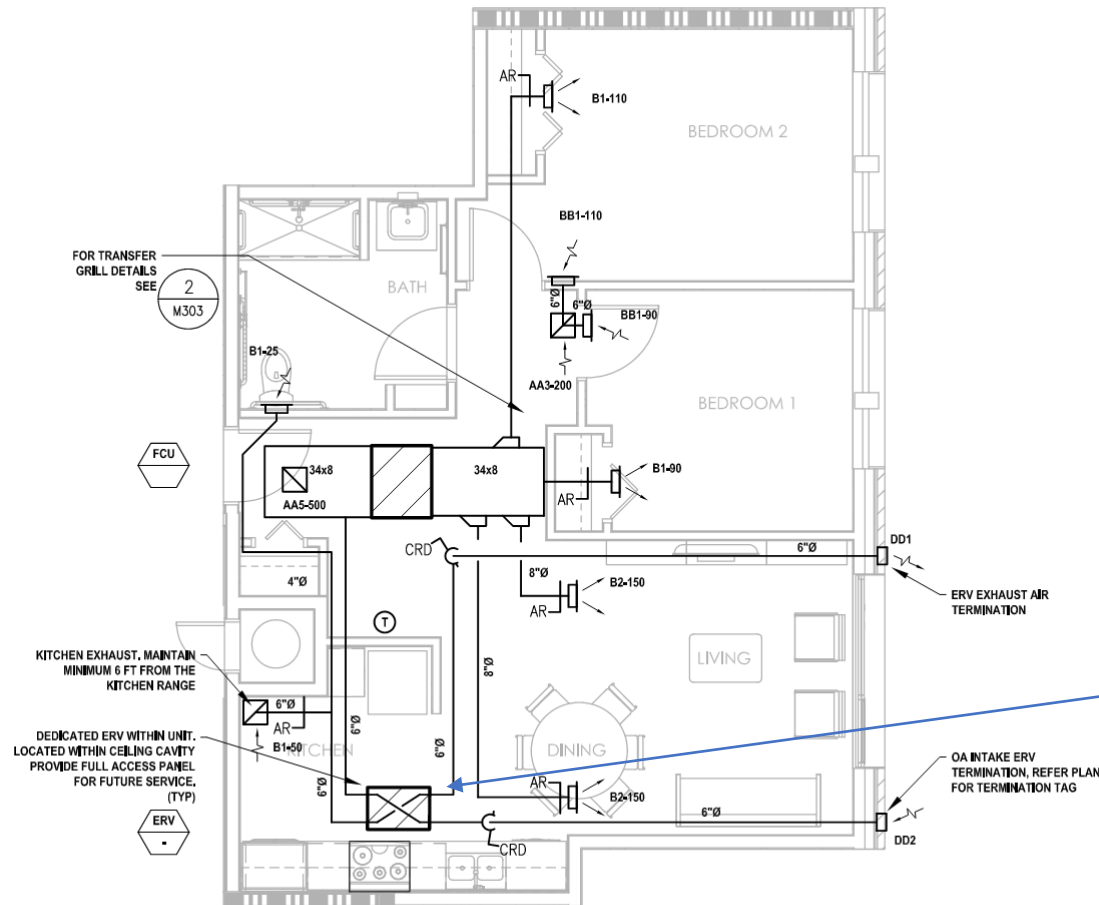

### ERV SYSTEM FEATURES:

- Each DU to have dedicated ERV, system to operate continuously to provide partially tempered air to FCU return plenum.
- MERV-8 or MERV-13 filtration available for Ventilation Outdoor Air.
- 75%+ Sensible Heat Recovery Efficiency
- Integral ECM Blower motor assembly for adjustment and energy efficiency.



# E+ Highland: Plumbing Systems

## Central air source heat pump – domestic hot water production

System Schematic image<sup>\*1</sup>

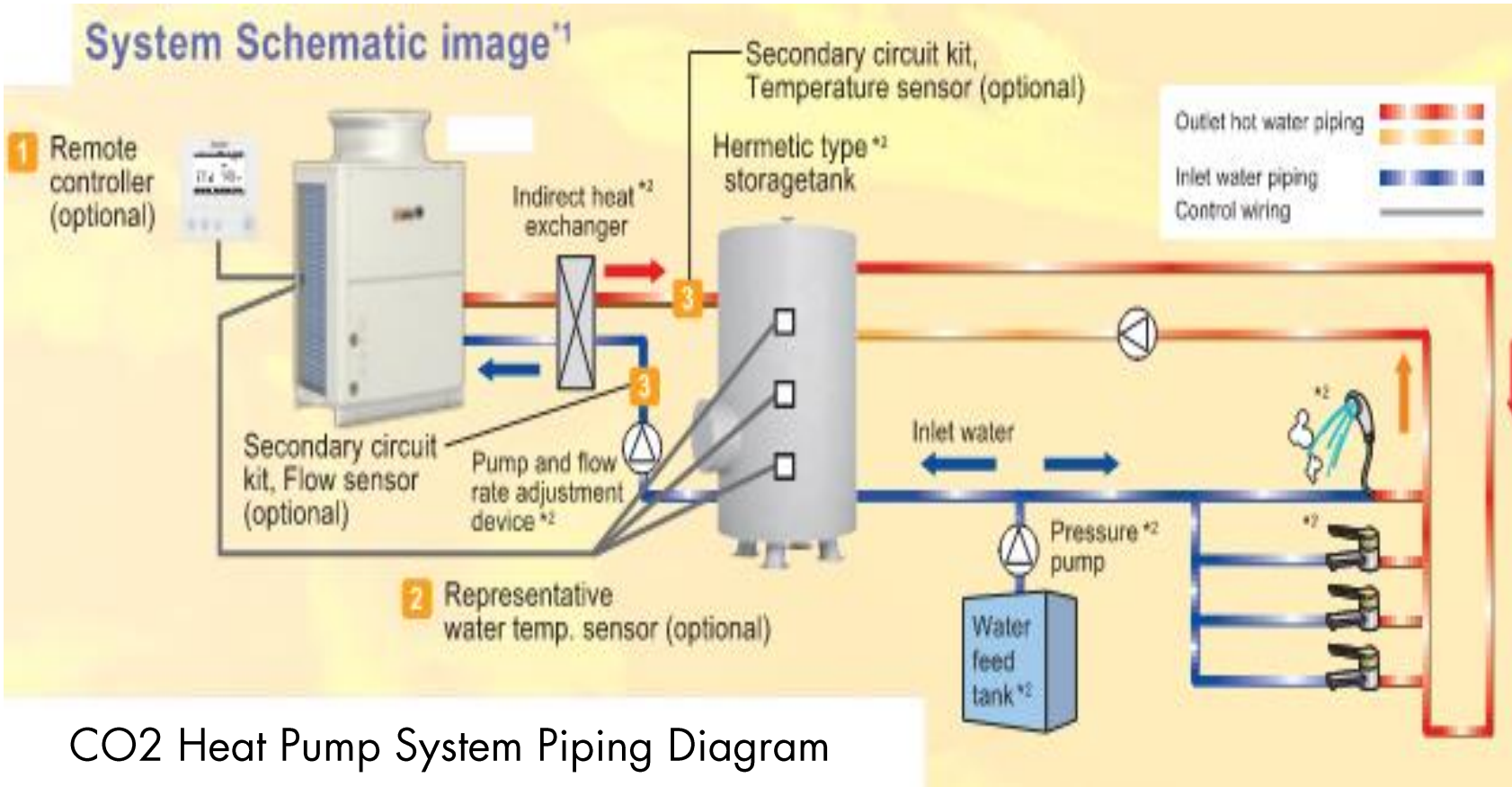

CO2 Heat Pump System Piping Diagram

## Domestic Hot Water (DHW) System:

- 144 MBTUH, CO2 Heat Pump Module
- 285 Storage Tank
- 150 Gallon Electric Swing Tank
- Master Digital Tempering Valve
- Heat Exchanger
- Isolated Piping Loops (Exterior/Non-Potable & Interior Potable)
- Controls Integrated within Central Controller
- 4.1 COP Listed Performance

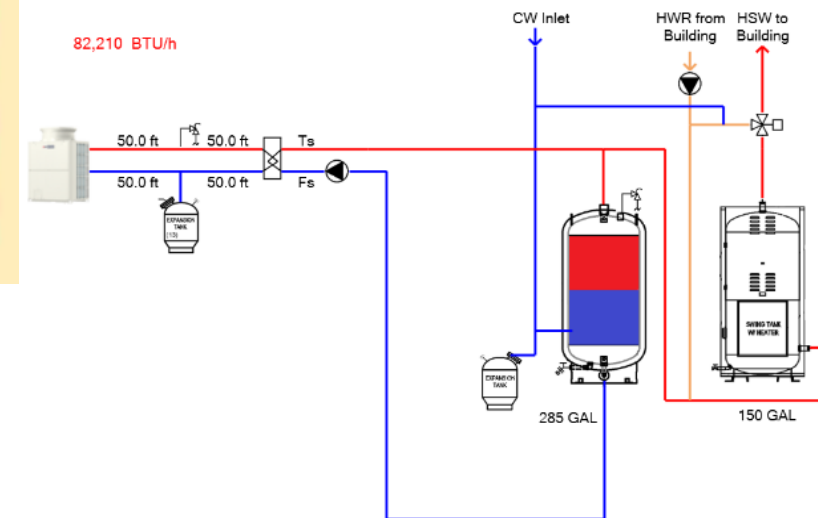



# 37 Wales: Plumbing Systems

## Individual Heat Pump Domestic Hot Water Heaters

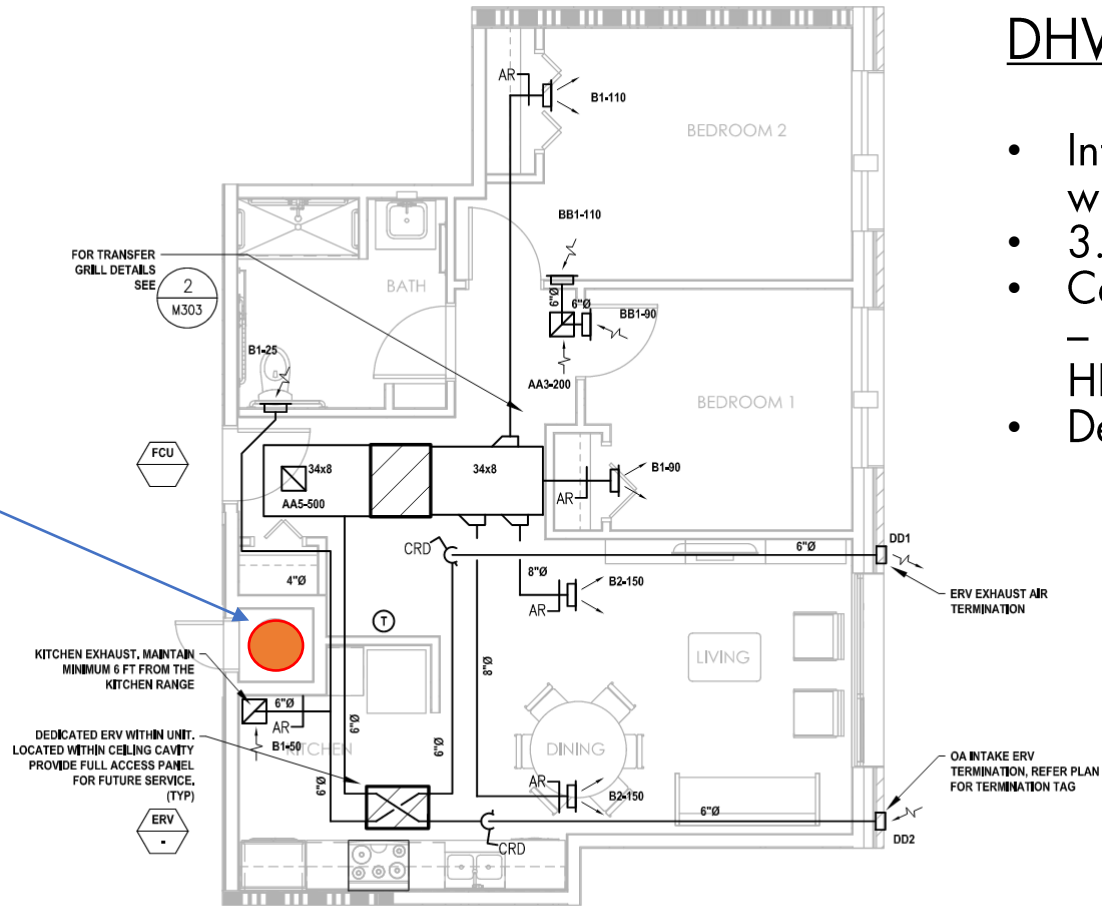

3 TYPICAL 2BR UNIT MECHANICAL PLAN - GROUP 2B  
M201 SCALE: 1/4" = 1'-0"

UNITS: 105

### DHW System Features:

- Integral R-134 Heat Pump Assembly with Electric Heat Resistance element.
- 3.45 UEF Rating
- Can be operating as Efficiency Mode – Heat Pump only, or Hybrid Mode – HP & Electric Water Heater Element
- Dedicated System Controller



ELECTRONIC USER INTERFACE

# E+ Highland & 37 Wales: Controls

VRF/VRV Site Control Diagram – “Stand-Alone”

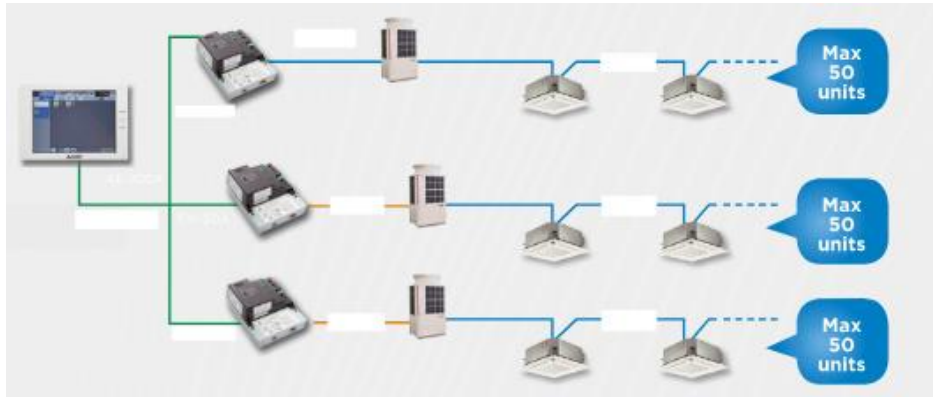

## HVAC System Controls:

- Control systems range based on Project Scale and Owner Requirements.
- **Stand Alone System Controls**  
Local VRF/VRV Equipment is controlled by a dedicated controller or central panel on site.
- **Central Building Management System (BMS)**  
HVAC Systems on site are controlled via a BMS, also known as a “Direct Digital Controls” (DDC) system which allows all equipment to be integrated within one control system platform. BMS or DDC systems may also control lighting or other systems on site and can be designed to accommodate different requirements for each project.

Central BMS Control Diagram – “Cloud Based BMS”

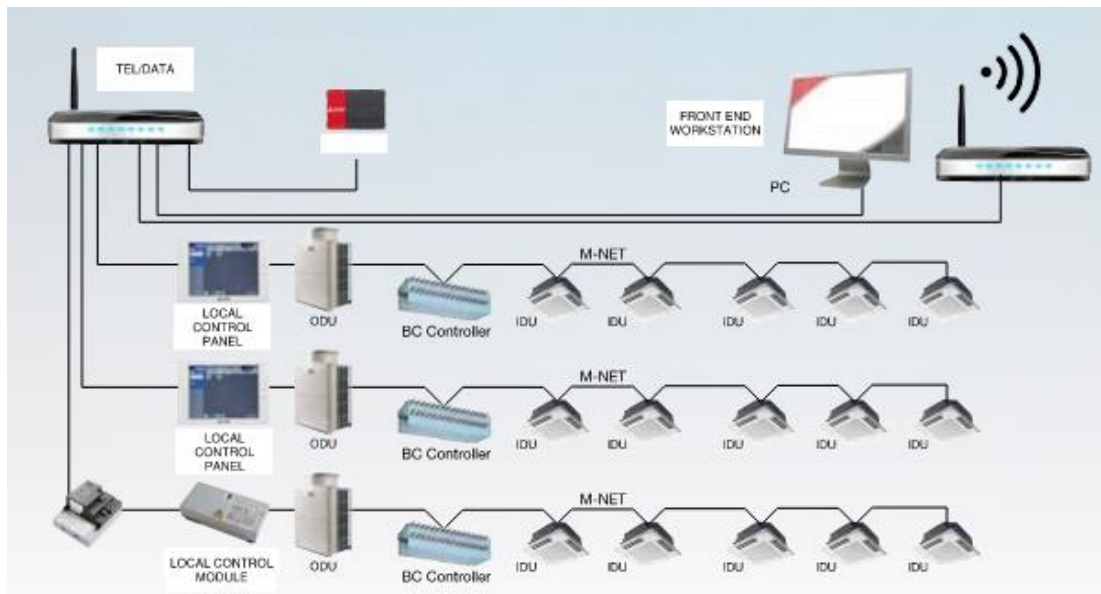

FCU Thermostat Controller Example

# Systems: Refrigerants & Environmental Impact

## Refrigerants and Heat Pump Technology Advancements for lower system GWP

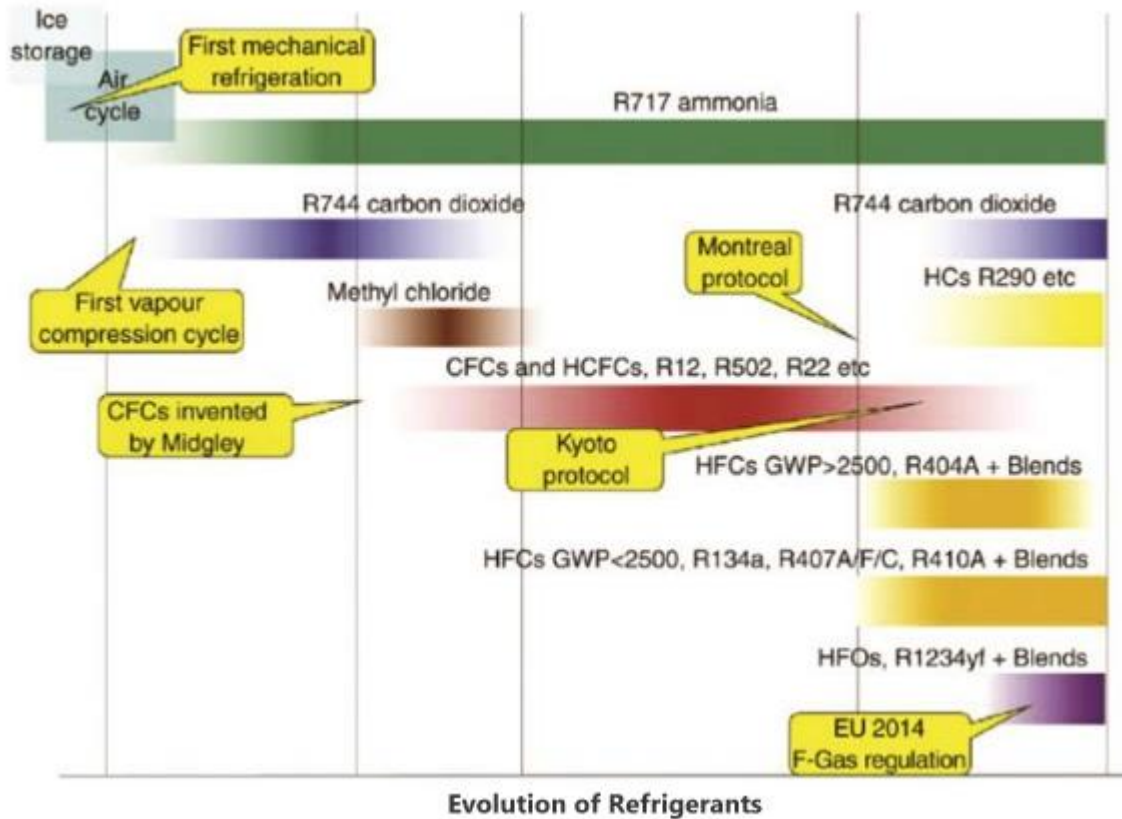

	HYDROFLUOROCARBONS (R134A)	HYDROCARBONS Propane (R290)	CARBON DIOXIDE CO <sub>2</sub> (R744)	AMMONIA NH <sub>3</sub> (R717)
Refrigerant Type	Synthetic		Natural	
ODP			0	
GWP (100 year)	1430	3	1	0
Flammability	None	High	None	Low
Toxicity	Low (no identified toxicity at concentrations ≤ 400 ppm)			High (evidence of toxicity at concentrations below 400 ppm)
Typical Operating Pressure Range	0.6 - 6.7 bar	10 - 50 bar	10 - 50 bar	2.9 - 13.5 bar
Component Challenge		Flammability	High Pressure	Material Compatibility Corrosion
Pressure Switch Technology Solution		Explosion Proof Sealing	Heavy Duty Design	Hard Anodized

Comparison of Common Refrigerants

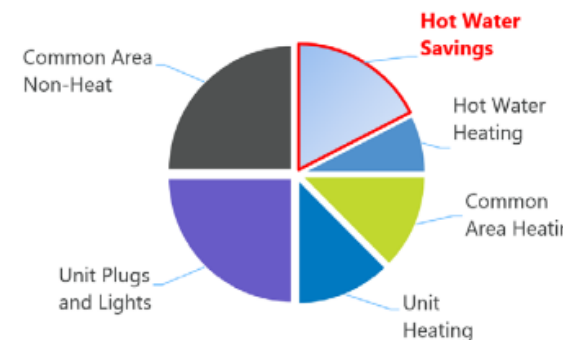

Heat pump water heaters, or HPWH, have the potential to reduce the energy used for water heating by approximately a factor of three if properly designed. Figure 1 shows an energy-use pie chart of a typical multifamily building, and the savings that can be expected from a correctly designed and operated HPWH system.

Figure 1. Energy savings with heat pump water heaters for a typically multifamily installation.

# Systems Consideration: Regenerative Drive

## Elevator Regenerative Drive Systems

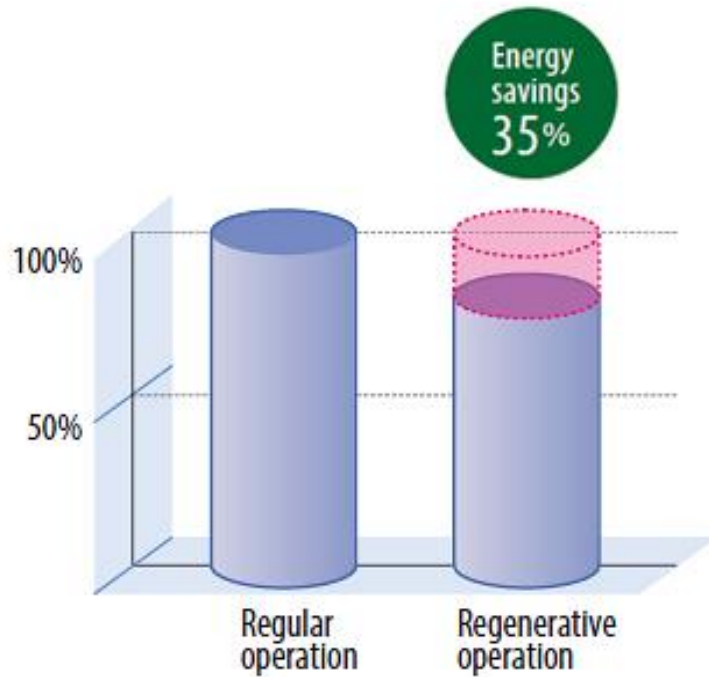

Standard Operation vs. Regen Drive Potential Energy Savings

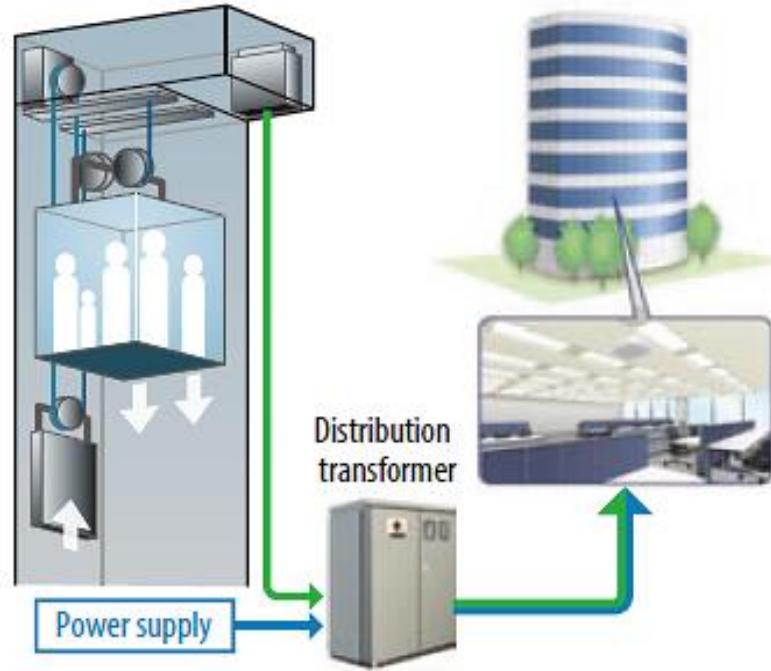

Elevator Regen Drive Diagram

### Regen Drive System:

- Generates power while elevator cart is descending.
- Converts "wasted" energy while the elevator cart is braking or slowing down into electrical energy.
- Distributes energy back to local electrical distribution system to offset local lighting or equipment electrical loads.



# Systems Consideration: Solar Thermal

**With Solar Thermal on the roof**  
(Site Energy = 0.6kBTU/Ft<sup>2</sup>yr)

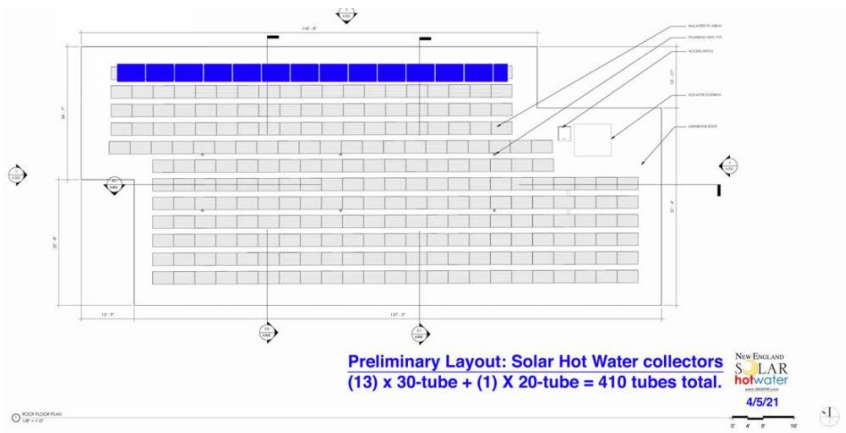

**Without Solar Thermal on the roof**  
(Site Energy = 0.01kBTU/Ft<sup>2</sup>yr)

- Efficiency of the panels, and size/count varies
- Duplicate DHW systems
- Extra water storage
- Extra structure required for 800 gal storage tank
- Did not contribute to the overall goal of Energy positive

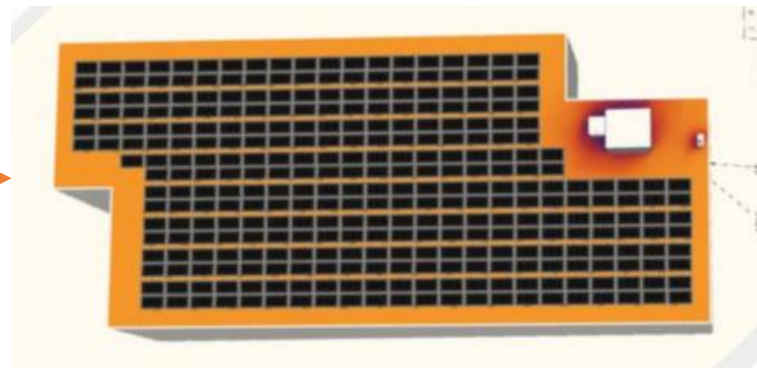
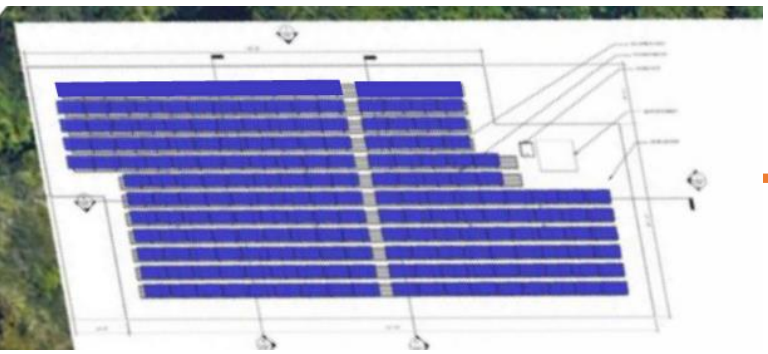

# Systems: The Bottom Line

## 1. Determine System HVAC Approach and Utility Infrastructure early in Project:

## 2. Ventilation Is Key:

- **Roof Mounted Central Ventilation Systems** Roof Mounted ERV systems may help to maximize interior space but will reduce the project's ability to generate solar power. Power consumption is on house panel, longer duct run needed = more fan power.
- **Indoor Central ERVs per Floor (E+ Highland)** Central ERV's at Building interior will maximize the solar generation on site as well as omit the fire-rated shafts and SFD damper requirements. However, they will also require more interior space to house the mechanical equipment. Power consumption for Central ERV's is on fed from house panel, not apartment load center. Shorter duct runs needed = lower pressure drop over system = less fan power required.
- **Individual ERVs per Dwelling Unit (37 Wales)** Dedicated ERV's may reduce the amount of interior area occupied by mechanical equipment as well as eliminate the need for a vertical fire-rated shafts and smoke/fire dampers. However, they will increase the quantity of envelope penetrations, which may be more difficult to air seal. Power consumption is on residential panel, short duct runs = less fan power.

## 3. Review emerging technologies and how they can be implemented within projects to achieve lower energy targets.

## 4. Continuous project communication is required for successful system designs.



# Takeaways

## Architects' Takeaway:

- Net Positive is HARD!  
(for multifamily)
- All electric buildings need financial incentives for PV especially for nonprofit clients/affordable housing
- Communication is KEY between Designer + CPHC + Engineers – more than normal!
- INNOVATION needed on lights, occupancy sensors, plug loads, appliances
- Tighter regulations are pushing everyone to be better designers, and more municipalities need to adopt stricter energy goals to move the whole industry forward

## Engineer's Takeaway:

- Successful projects require clear communication from all team members on project financial goals and funding requirements.
- Achieving PH Certification and 100% Electrically operated systems will require the latest system technologies and design strategies to maximize system efficiencies and reduce energy consumption onsite.
- Ventilation is a critical element within PH projects and will require different system design strategies based on project requirements.
- As emerging technologies enter the market, it is critical that Engineers and Designers review new system options, documented equipment performances and overall system requirements for successful integration, especially Case Study materials and Manufacturer Testing information.
- The need for Post-installation system commissioning, maintenance and monitoring is critical to ensure proper operation and energy conservation once systems are operational.

An architectural rendering of a modern, multi-story building. The building features a prominent wooden facade on the upper levels and large glass windows. The ground floor has a glass entrance with a small canopy. The address "273 HIGHLAND" is visible above the entrance. The scene is set against a clear blue sky with some light clouds. There are trees and a low wall in the foreground.

Thank you!  
Questions?

Gabriela Shelburne  
gabrielas@studiogarchitects.com

Keihly Moore  
keihlym@studiogarchitects.com

Drew Wilkinson  
dreww@ns-engineering.com